

Jan-Erik Frey
*Corporate Research
Industrial Communication*

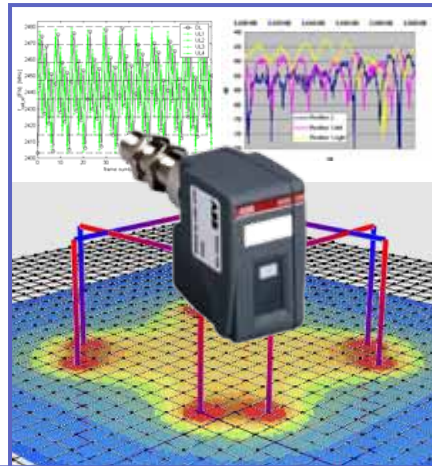

WISA – Wireless Control in Theory, Practice and Production



**Emerging Technologies and
Factory Automation**
September 18th 2008, Hamburg, Germany



- The Wiring Problem
- Manufacturing Control Requirements
- Wireless Communication
- Wireless Power
- Product Design Issues
- Applications
- Outlook



All “Wired Up” but No Where to Go

- Installation & Planning
 - “Cheap” sensors, but costly to plan and install
- Cable and Connector Wear
 - Causes intermittent failures that are hard to track
- Spare Capacity
 - To accommodate future plant modifications
- Flexibility
 - Design flexibility
 - Mobility
 - Tuning and upgrades



Wireless – Savings throughout the Plant Life Cycle

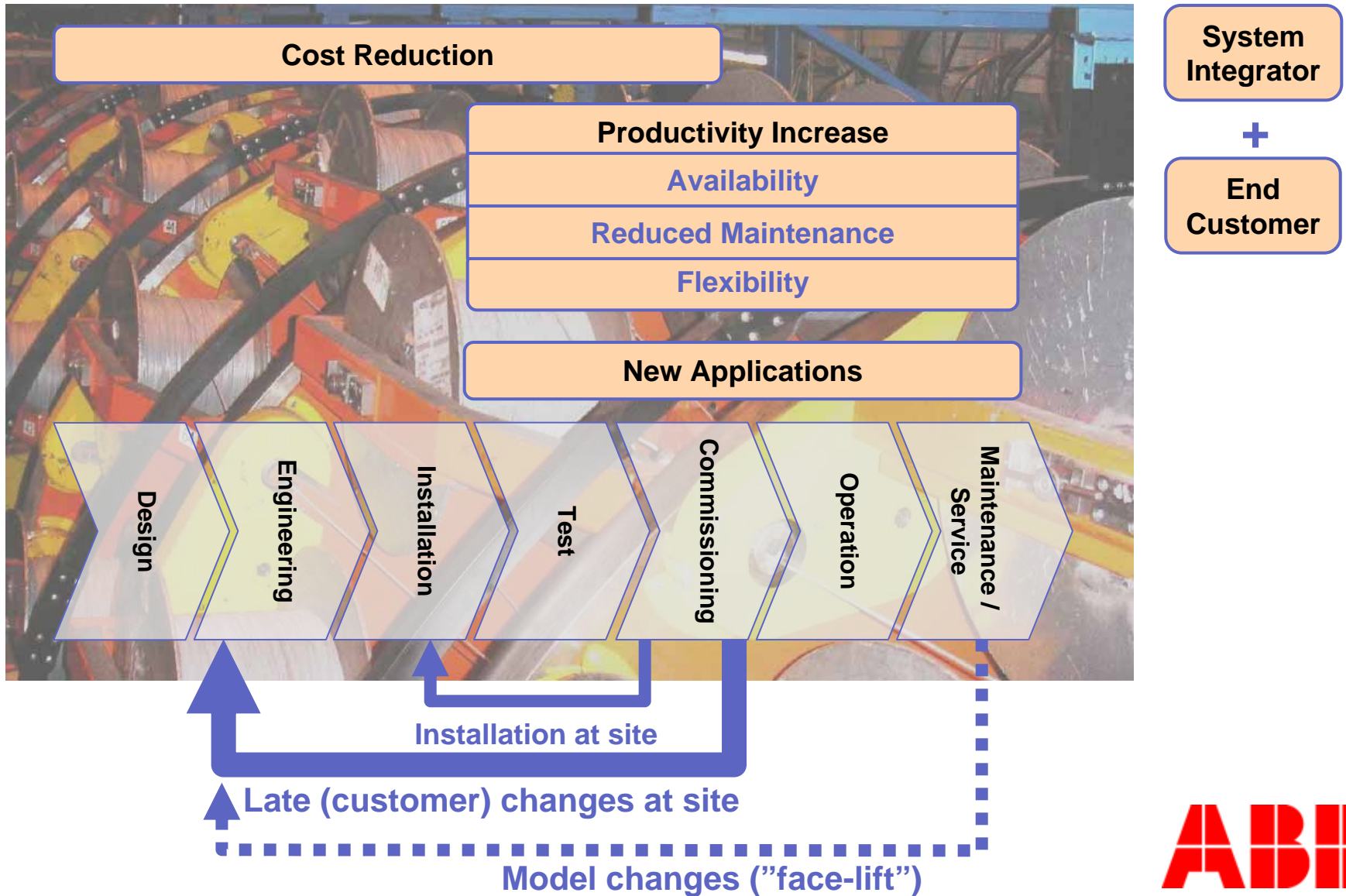

Address the "Right" Problem

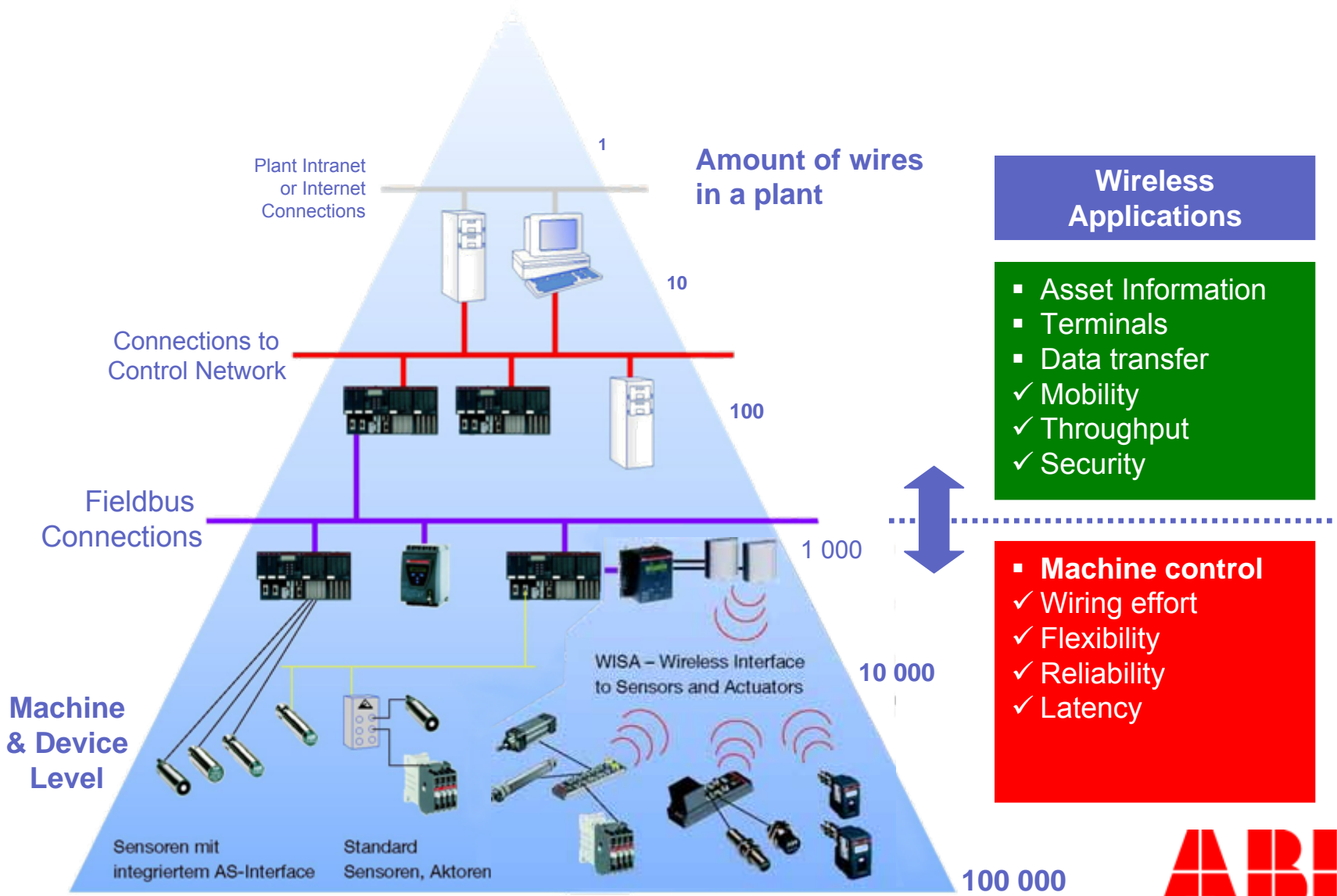

The Challenge

Machine control

- ✓ Wiring effort
- ✓ Flexibility
- ✓ Reliability
- ✓ Latency

Wireless (according to Webster's dictionary)
Having no wire; specif. (Elec.), designating, or pertaining to, a method of telegraphy, telephony, etc., in which the messages, etc., are transmitted through space by electric waves; as, a wireless message.

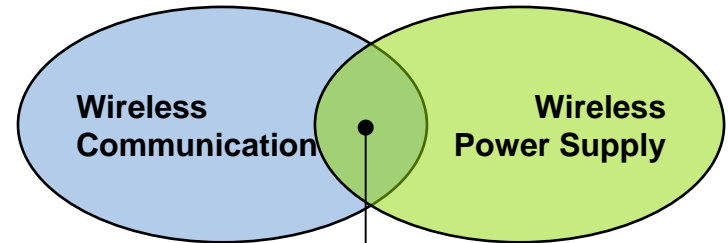

As reliable and robust as a wire

Autonomous (battery-less) operation

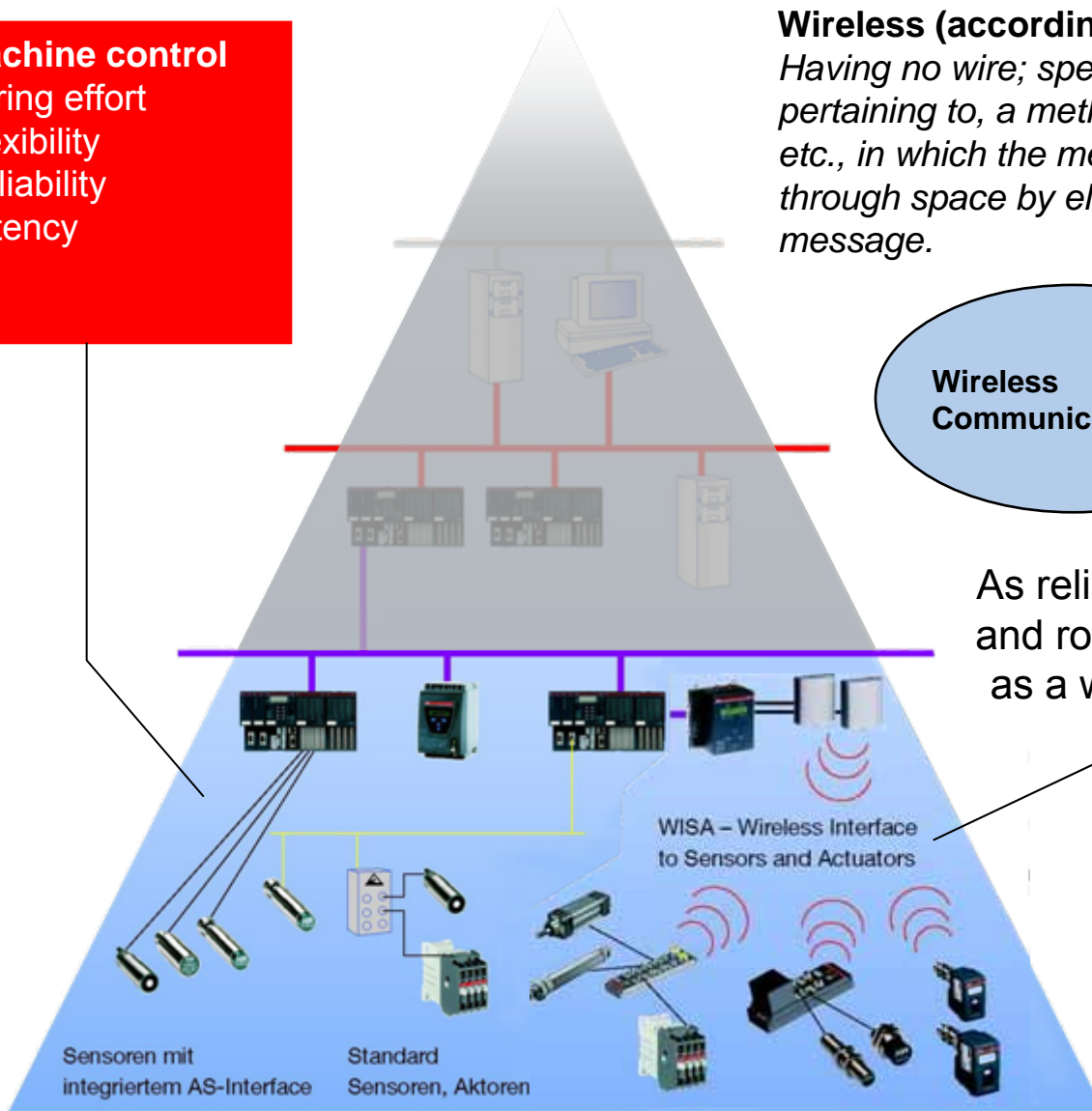

Factory Automation Key Requirements

- Reliable Communication
- Real-time Performance
- High Node Density
- Wireless Power
- Low Power
- Small size
- Low cost

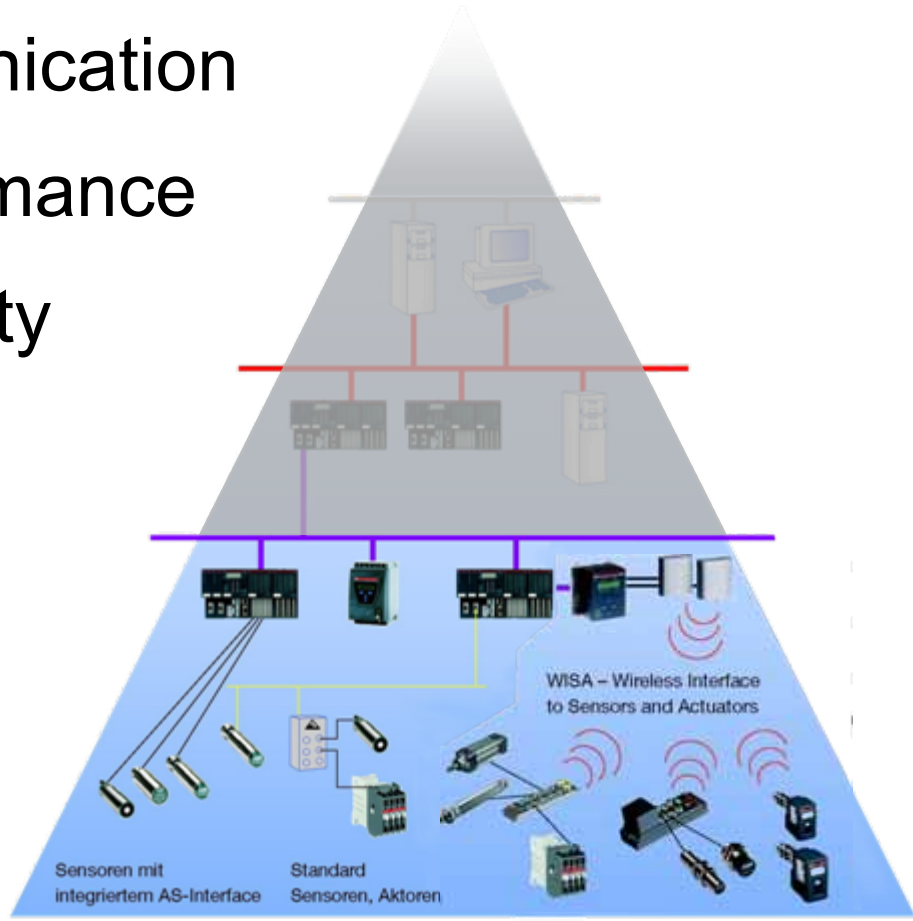

Requirements – High Node Density

50 - 300 nodes / cell

Node density 0,2 - 1 / m³

Use Case	Dimension (W x L x H) in m	Volume in m ³	Cells per factory hall	IO points per cell	assumed wireless nodes	IO point density in cell (1/ m ³)	Wireless node density in cell (1/m ³)	Factory hall size* in m ³	Wireless node density over factory hall (1/m ³)	IO density in factory hall (1/m ³)
Robot Manufacturing Cell	8 x 8 x 2,5	160	40	400	40	3	0,25	12800	0,13	1,25
Roundtable Production Cell	8 x 7 x 2,5	140	50	300	100	2	0,71	14000	0,36	1,07

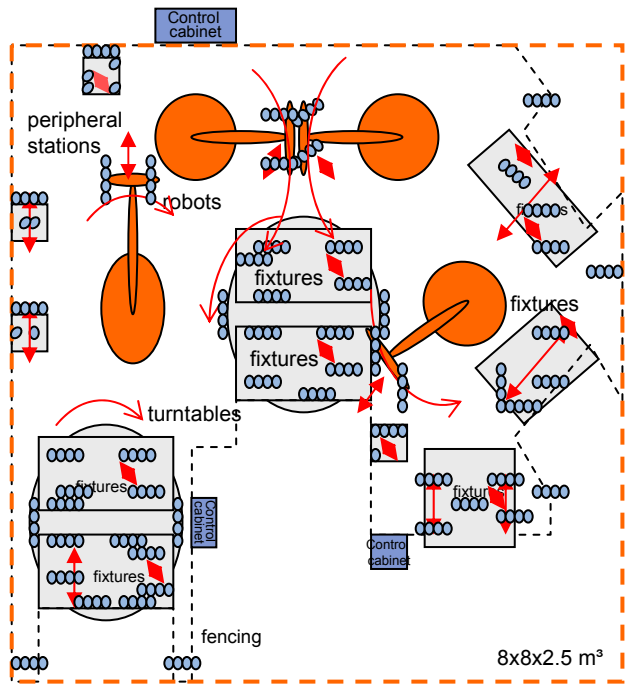

Robot Manufacturing Cell
Machine cycle 10 s

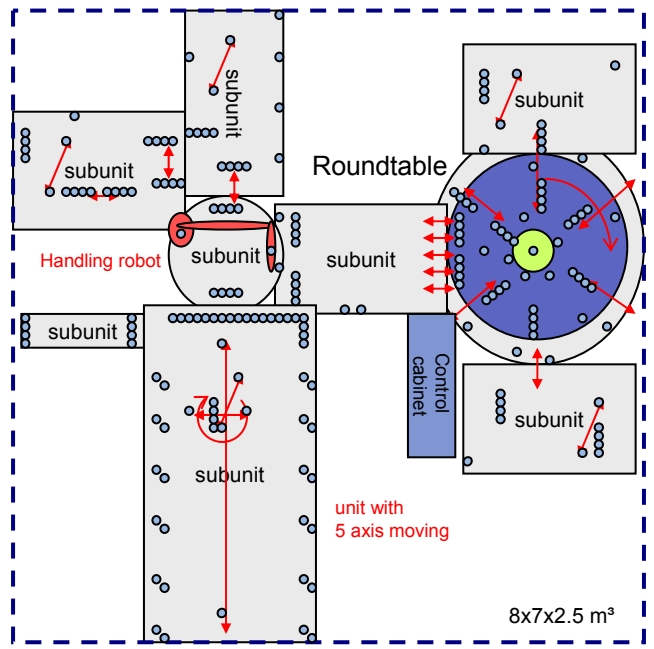

Roundtable Production Cell
Machine cycle 1 s



● Node ↗ Moving axes



Requirements – Real-time Performance

Roundtable Production Cell

- 1 production step per second
 - ➔ min. 2 events / second (typ.)
- 100 wireless nodes (typ. per cell)
 - ➔ 720 000 telegrams per hour*
 - ➔ 17 Mio. telegrams per day (3 shift production)
 - ➔ **5 * 10e9 telegrams per year** (neglecting weekends)
- ➔ **Error rate has to be << 10e-9**
 - for not maintaining the designed real time limit (e.g. 15ms)
 - In real environments!



PLC cycle times:
5 – 50ms
(typ. 20ms)

Signals have to arrive **reliably** faster than that

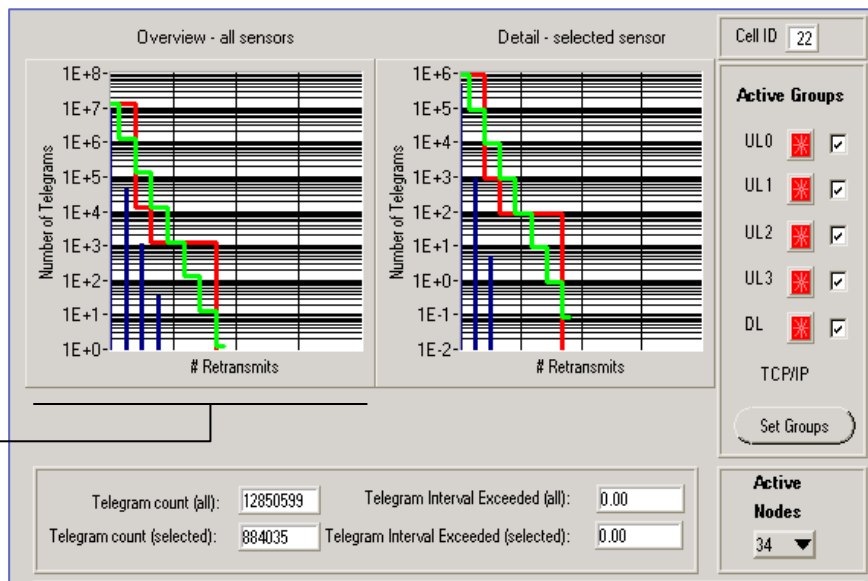

* Assumes digital sensors, concentrating IO nodes would have typ. 8 times more events !!



Requirements – Real-time Performance

Two critical cases dictate low latency:

- Low average latency
 - Many wireless nodes in a sequential logic control program lead to noticeable increase in machine cycle time
 - E.g., 40 nodes (typ. have independent events, spaced more than 10ms) at 10ms min. latency in WSAW
 - ➔ +0,4s cycle time
(+40% for a “1 second” production cycle)
- Low worst case latency
 - Time given by mechanical restrictions, speed
 - E.g., press applications with fixed mechanical curves
 - Rotating and moving machine parts

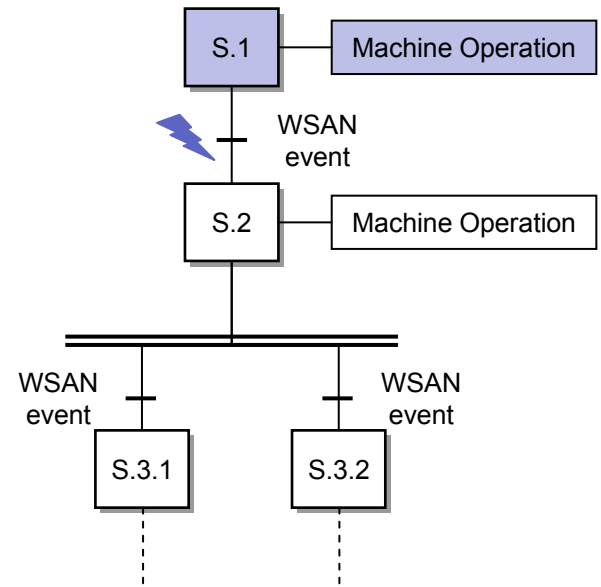

- Physical Layer = Bluetooth
 - ISM Frequency Band, 80 MHz at 2.4 GHz
 - Bit rate 1 Mb/s (Bluetooth), $T_{\text{bit}} = 1 \mu\text{s}$.
 - Transmit power 1 mW

- New MAC: Time Division Multiple Access (TDMA)
 - frame length $T_{\text{frame}} = 2.048 \text{ ms}$
 - 32 uplink slots per frame ($T_{\text{slot}} = 64 \mu\text{s}$), each slot fix assigned to one node
 - 4 parallel uplinks → 4·30 nodes / cell

- Frequency Division Duplex (FDD)
 - downlink/uplink duplex spacing $\geq 22 \text{ MHz}$

- Frequency Hopping (FH)
 - frame-by-frame frequency hopping
 - synchronous hopping of downlink and uplinks
 - optimized frequency hopping sequence

- Antenna Switching
 - frame-by-frame switching of base station antennas
 - left- and right-circularly polarized base station antennas

- Automatic Repeat Request ARQ
 - up to 7 (re-)transmissions within 15 ms

Reliable Communication

Real-time Performance

Node Density

Low Power

Cost



Medium Access and Re-transmission

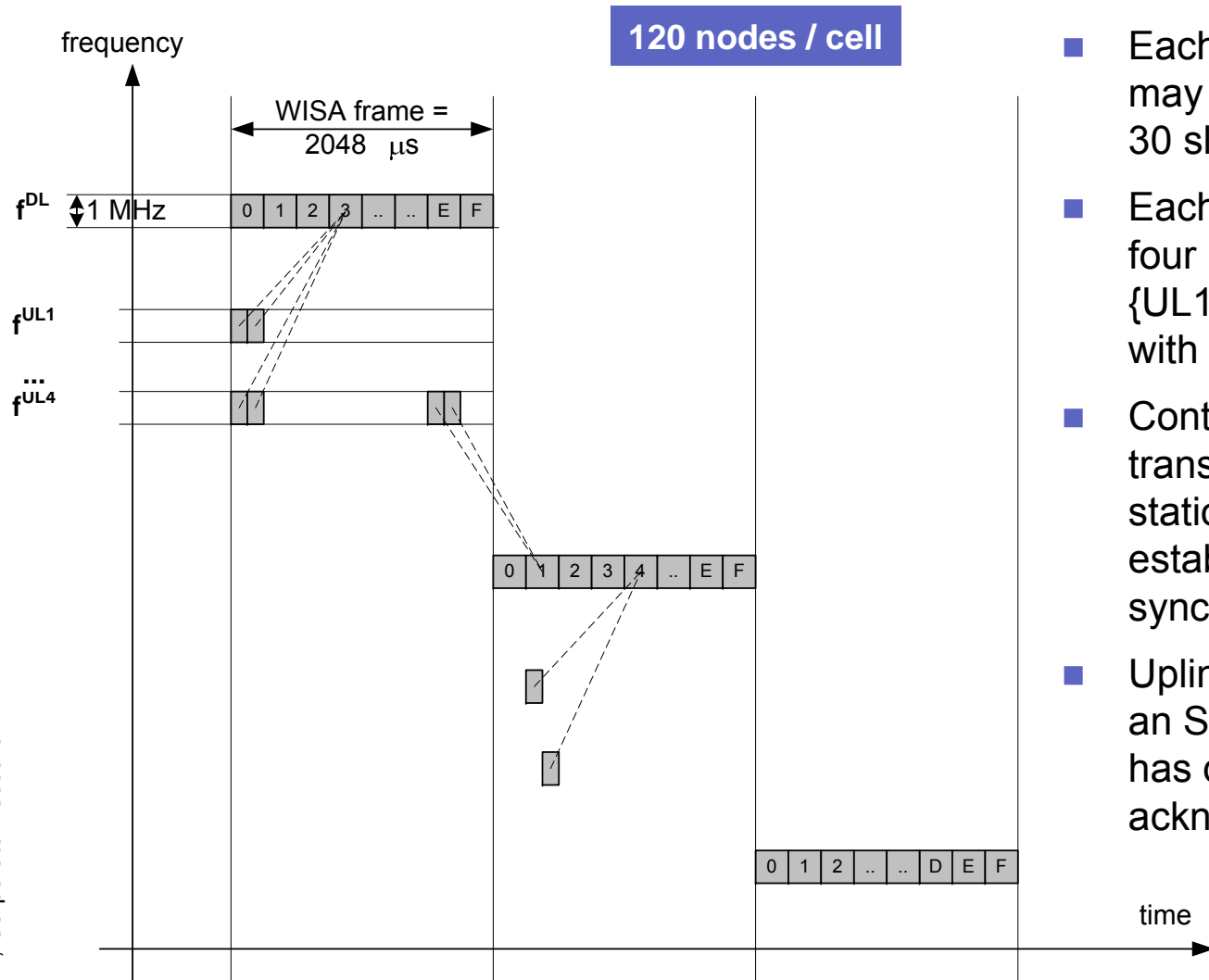

- Each sensor/actuator (S/A) may transmit in one out of 30 slots per frame
- Each S/A is part of one of four uplink groups {UL1, UL2, UL3, UL4} with separate frequencies
- Continuous downlink (DL) transmission (from the base station) for the purpose of establishing frame and slot synchronization of the S/A
- Uplink transmissions from an S/A occurs only when it has data or an acknowledgment to send

Frequency Hopping

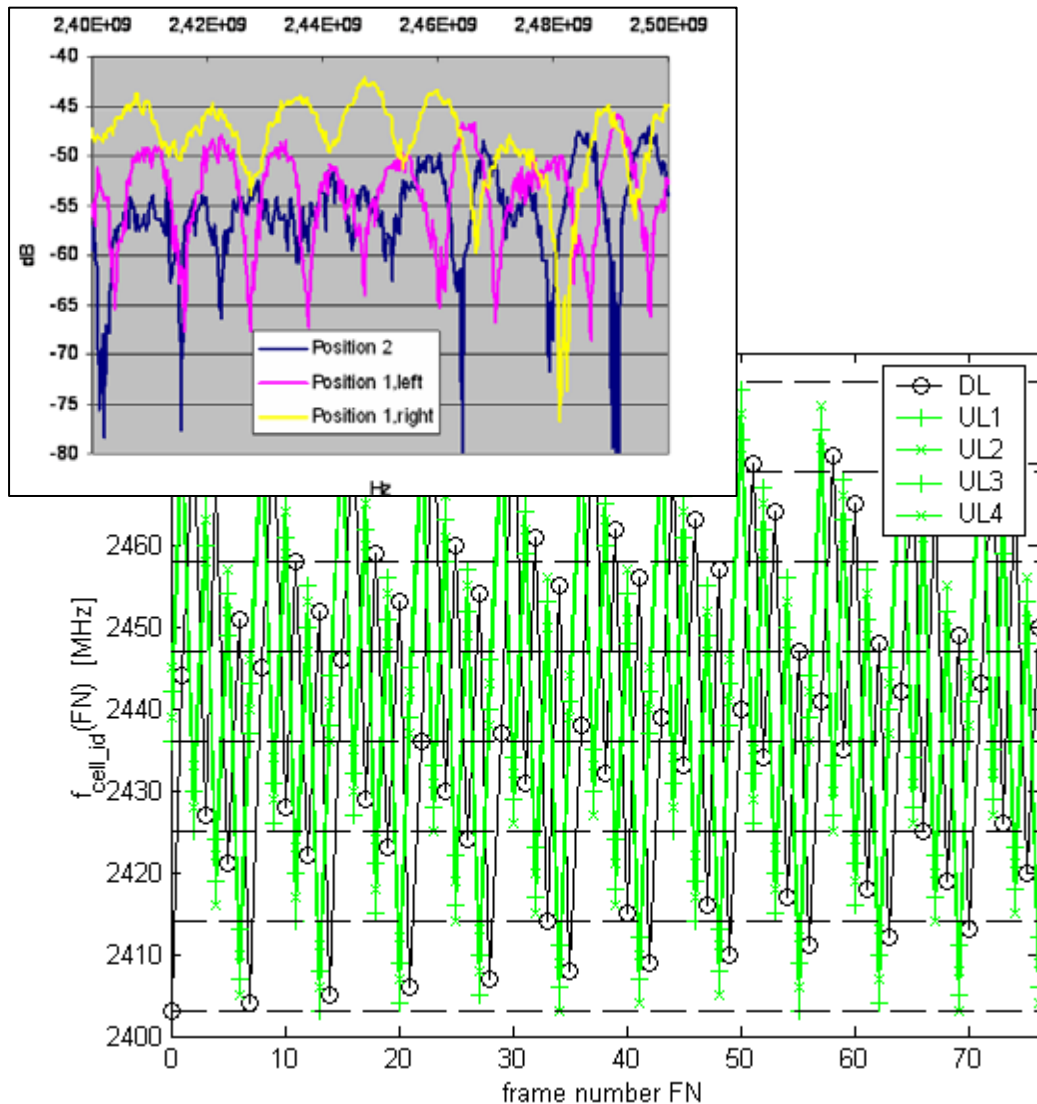

- Wide-band frequency hopping to battle against
 - Frequency-depending attenuation
 - Interference from other users in the 2.4 GHz band
- WISA Frequency hopping
 - Hop over available 80 MHz, bins = 1 MHz (Bluetooth)
 - Successive hops should be spaced by ≥ 11 MHz
 - The (duplex-) spacing between downlink and uplink frequencies is three sub-bands apart
 - The four concurrent uplinks are in the same sub band and hop with a fixed spacing of 3 MHz apart

Multi-cell Operation

- Each cell uses the entire 2.4 GHz ISM band of 80 MHz, without any need for inter-cell coordination, except that a different cell_id has to be set in each cell
- Where cells operate in close proximity, or are even co-located, the interference depends on the correlation properties of the frequency hopping sequences and the cell traffic load
- The WISA frequency hopping scheme ensures a low cross-correlation between cells

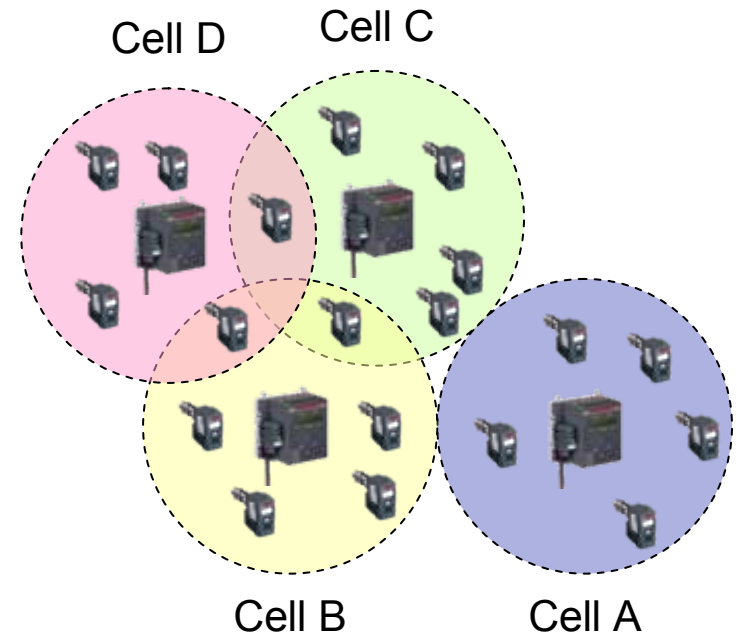
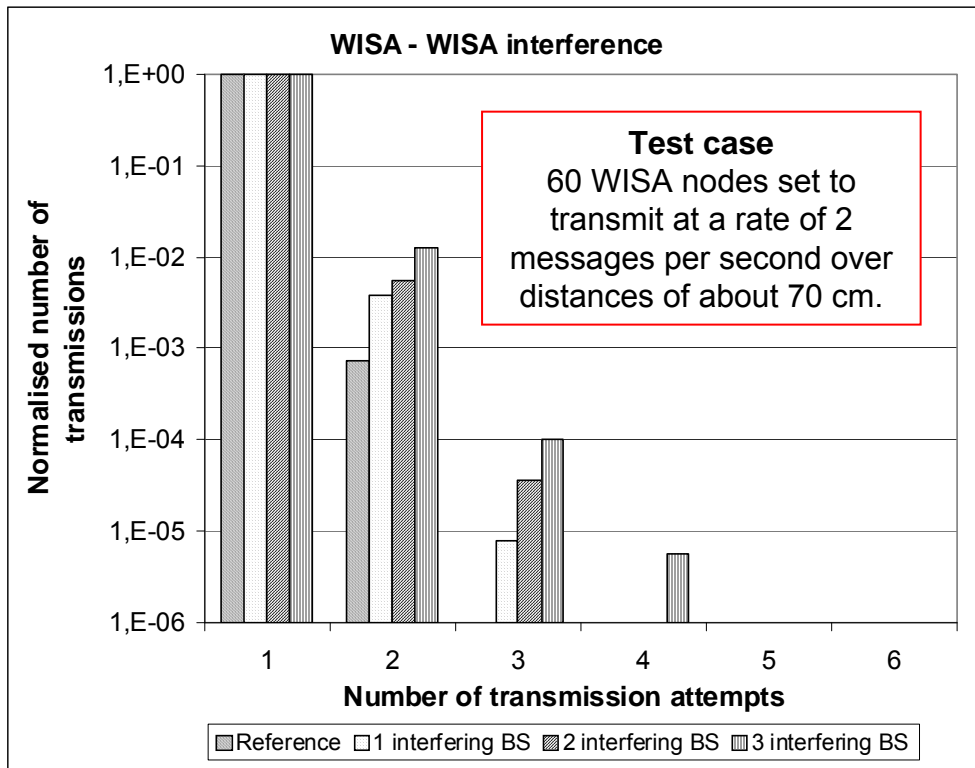

WISA – Yet another Wireless “Wheel”?

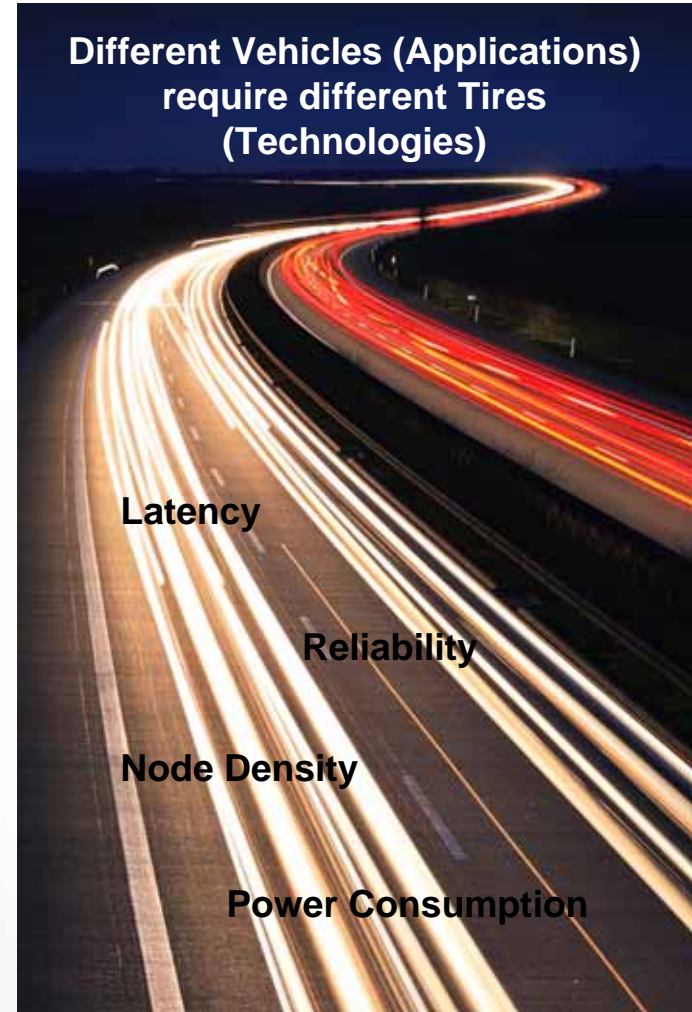

Technology Comparison – Requirements

■ Requirements: Quantitative Comparison

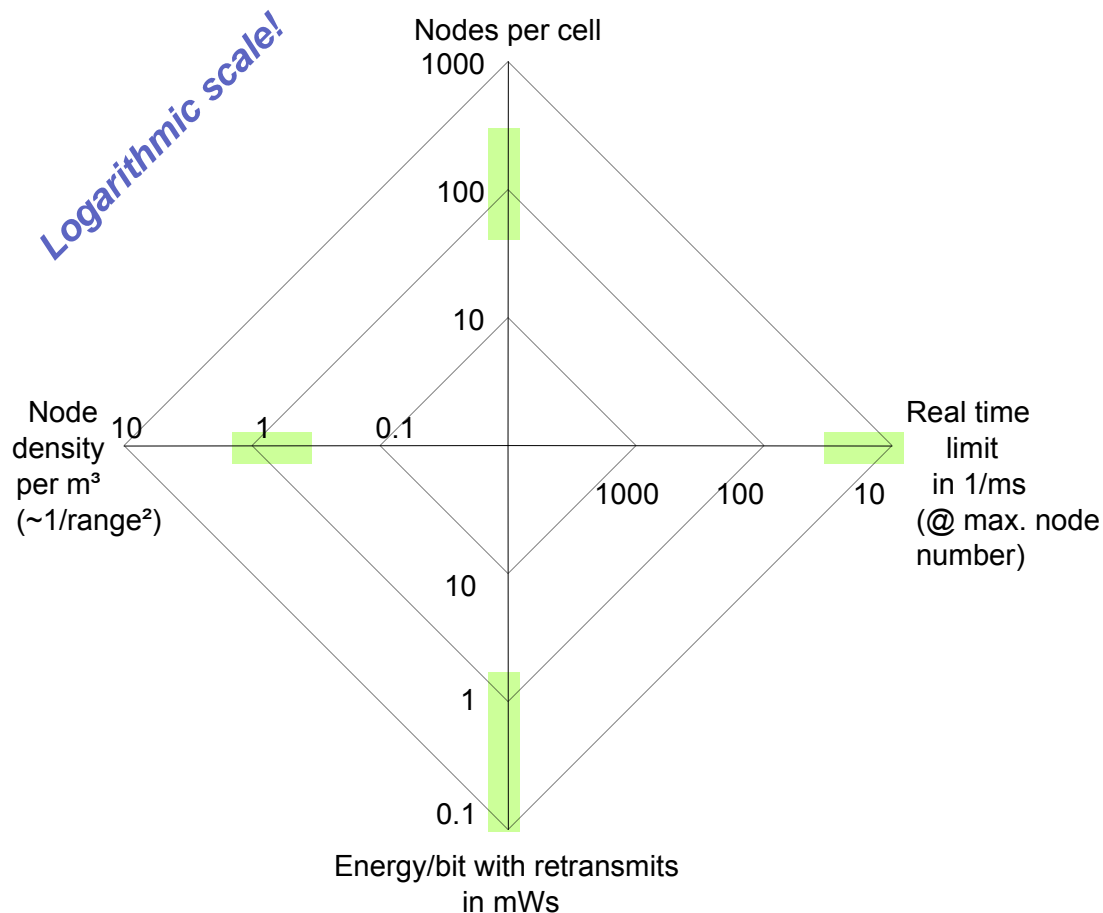

- Nodes per cell
 - Wireless proximity switches (1bit)
- Node density
 - Number of nodes without significant performance change
- Real-time limit
 - “Practically” guaranteed time delay (failure probability of 10⁻⁹).
- Energy/bit
 - Payload dependent

Technology Comparison – Bluetooth

Requirements: Quantitative Comparison Bluetooth

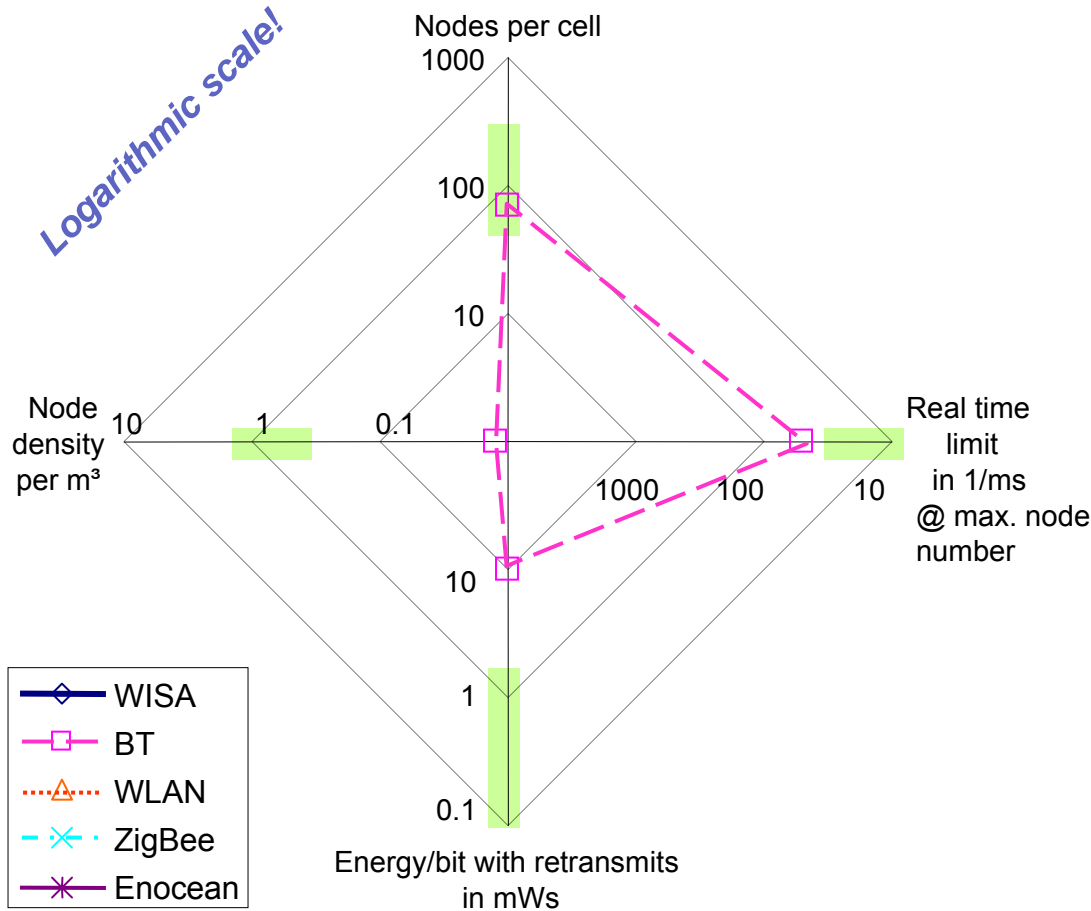

- Low node density due to long range (comp. to requirement)
- Polled system with time slots and large payload results in
 - High latency under realistic conditions with many nodes
 - High energy consumption

Technology Comparison – 802.11 WLAN

■ Requirements: Quantitative Comparison **WLAN**

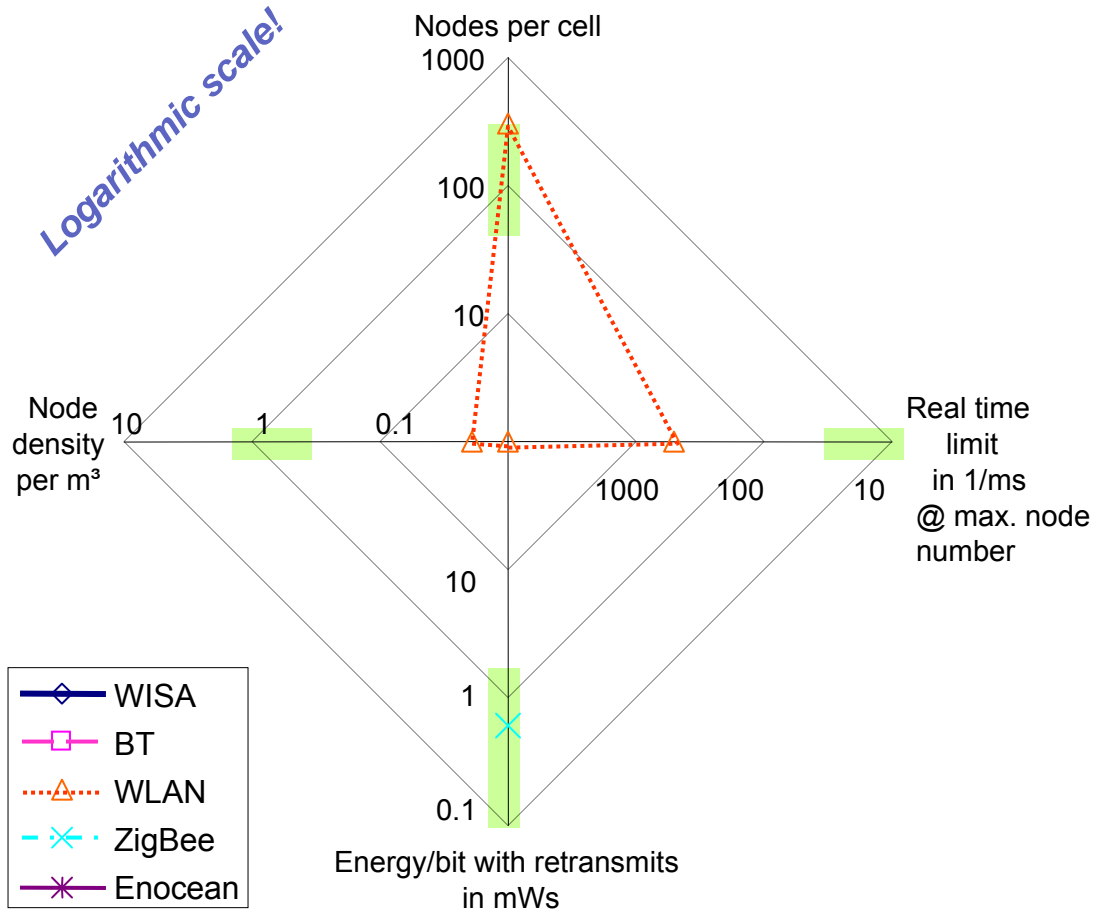

- Low node density due to long range
- High latency due to large frame size and CSMA/CA media access scheme
- Optimized for high throughput and low average latency



* Source: IEEE Industrial Electronics Magazine, Summer 2007

Technology Comparison – ZigBee

■ Requirements: Quantitative Comparison ZigBee

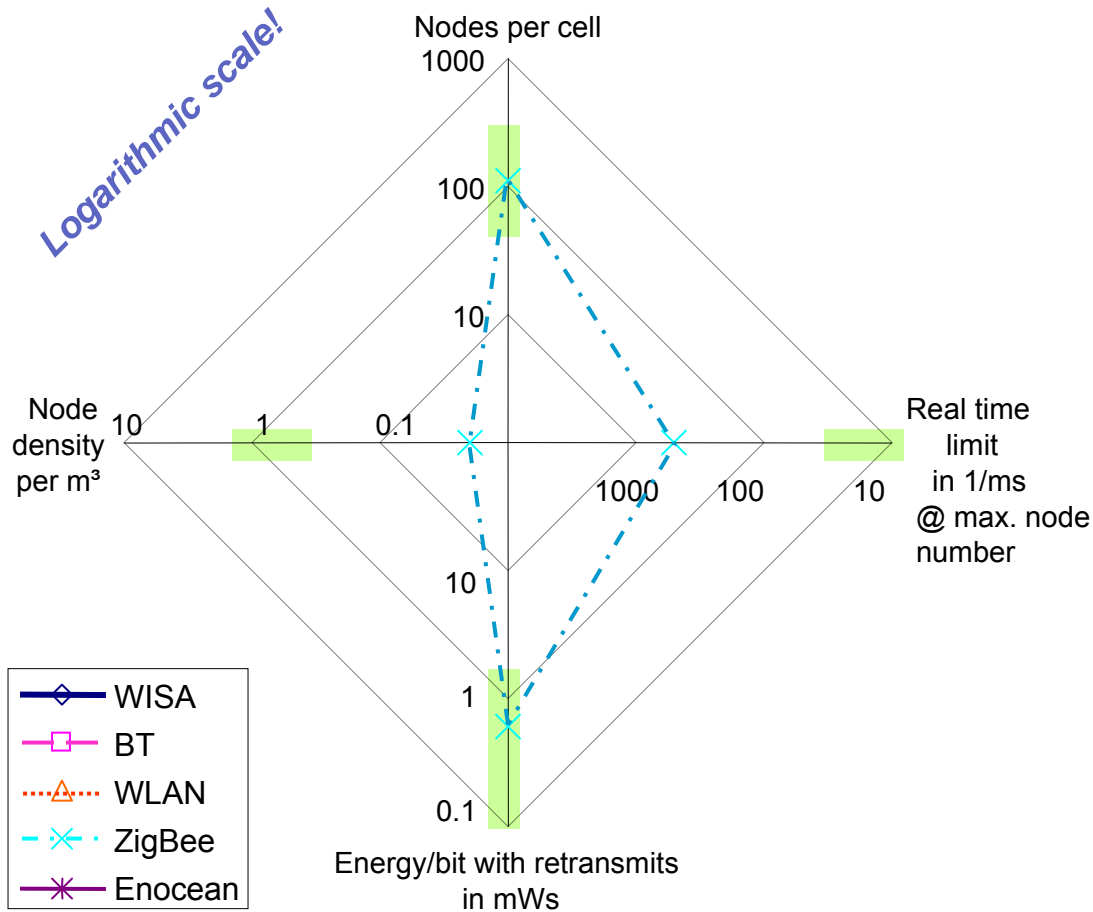

- Optimized for low energy consumption
- Real-time limits cannot practically be guaranteed
 - Long wake-up and channel access times
 - CSMA/CA media access scheme
 - Multi-hop architecture

* Source: IEEE Industrial Electronics Magazine, Summer 2007

Technology Comparison – *Enocean*

■ Requirements: Quantitative Comparison *Enocean*

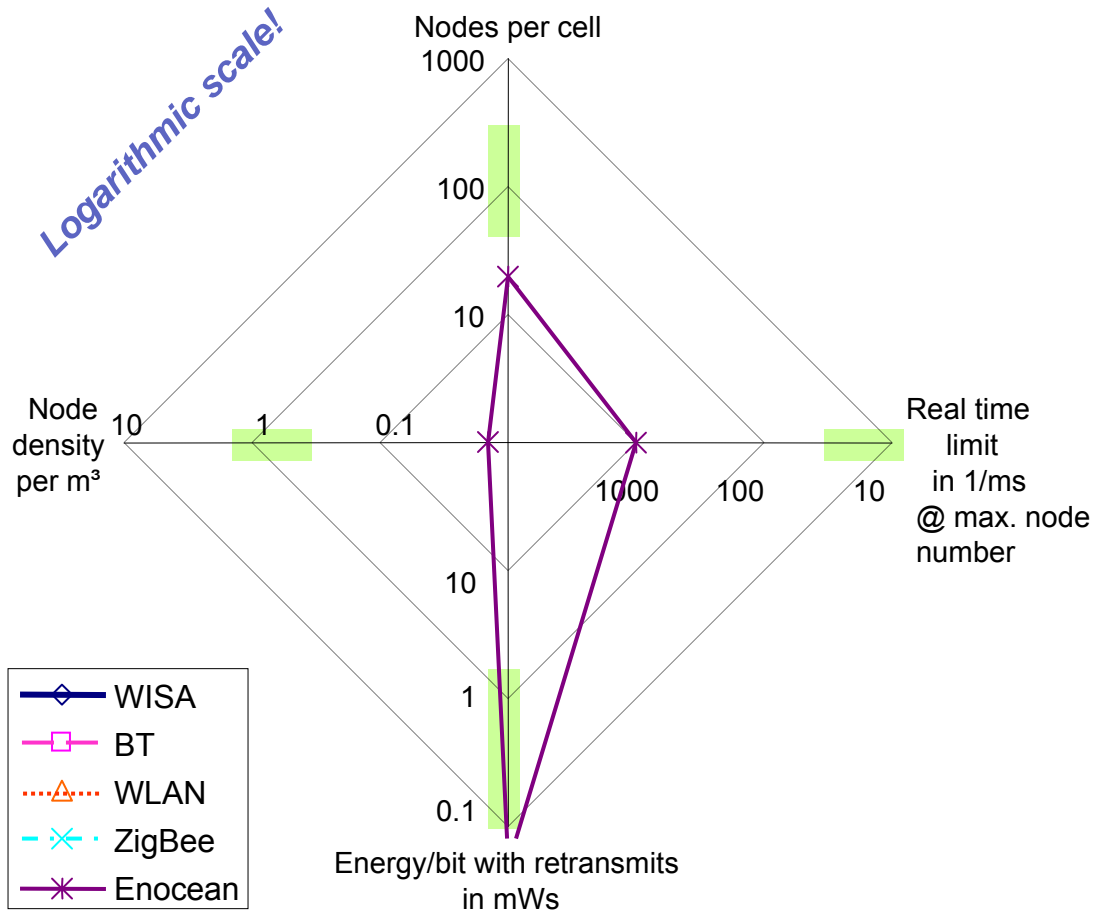

- Low maximum number of nodes per network
- Low number of coexistent networks
- Optimized for low energy consumption
- Real-time limits cannot practically be guaranteed

Technology Comparison – WISA

■ Requirements: Quantitative Comparison WISA

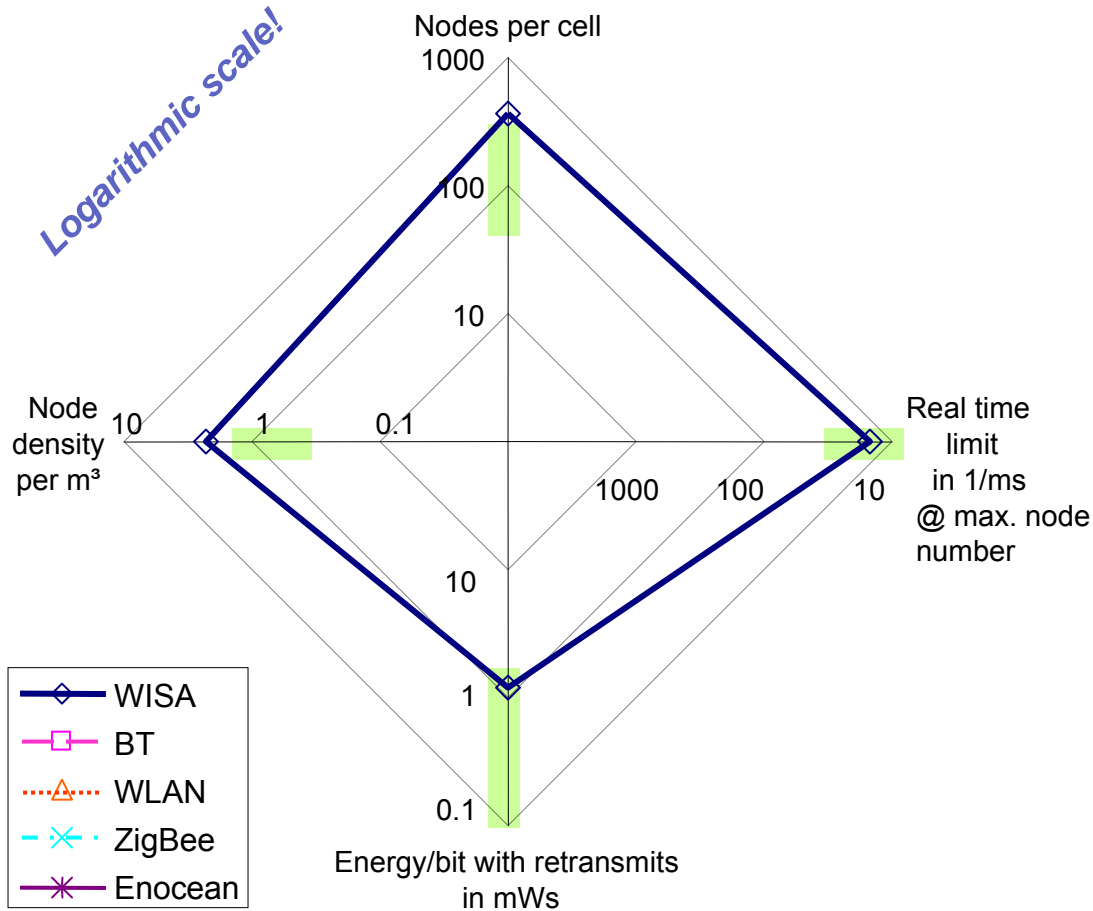

- Low latency
 - Deterministic medium access TDMA / FDD / FH, and ARQ
- High node density
 - FH sequences optimized for interference resistance, and with low inter-cell correlation

Technology Comparison – Summary

■ Requirements: Quantitative Comparison

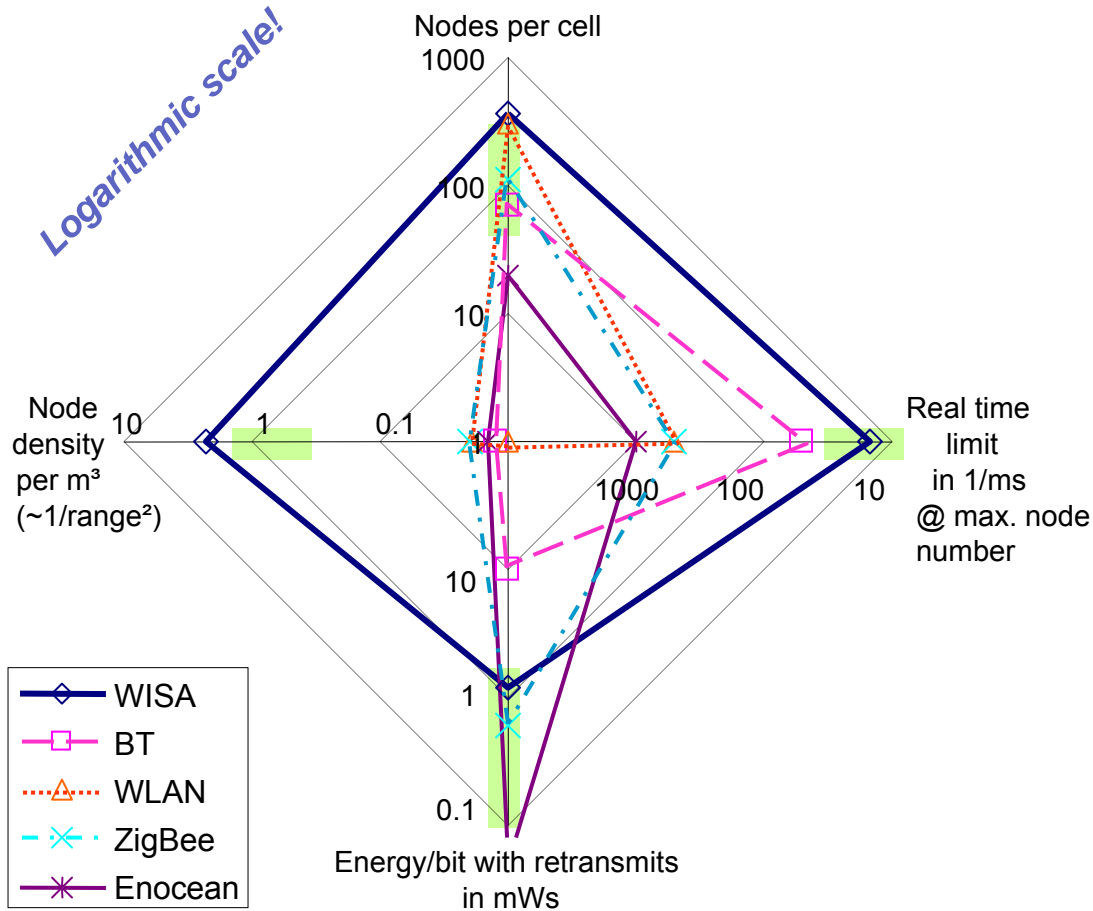

- Only WISA is able to achieve a node density capable of covering a whole plant
- For technologies like EnOcean, ZigBee, and WLAN, low failure probabilities are not generally possible due to their long range and contention-based media access

Cutting the Power Cord

- Power Demands
 - Dependent on duty cycle and losses associated with operation of sensor and electronics
 - WISA Target: 5 - 100 mW (single sensors vs. concentrators/actuators)
- Energy Buffers
 - To cope with time-varying input and output power
- Lifetime
 - 10 Years maintenance free operation
- Form Factor
 - Small size suitable for sensor retrofits
- Power Management
 - Manage availability, time behavior and output characteristics of the power source



Power Supply Technologies

Concept	Energy Conversion <i>Environment</i>	Energy Storage <i>Included</i>	Energy Distribution <i>Transmitted</i>
Technologies ◎ = Commercial availability	<ul style="list-style-type: none"> ◎ Photovoltaic ◎ Temperature gradient ◎ Vibrations ○ Human power ○ Wind / air flow ○ Pressure variations 	<ul style="list-style-type: none"> ◎ Primary Batteries ◎ Secondary Batteries ◎ Micro-fuel cells ◎ Ultra-capacitors ○ Micro-heat engines ○ Radioactive power sources 	<ul style="list-style-type: none"> ◎ Electromagnetic coupling ◎ RF radiation ○ Wired power grid ○ Acoustic waves ○ Optical
Power Levels	10 μ – 15 m W/cm ³	0,01 – 2 Wh/cm ³	μ W – kW (m – mm)
Deficiencies	Reliability	Maintenance	Electric field radiation Power level vs. range
Industrial Applications	Niche Applications	Portable/mobile user interface	Cell automation power supply



Wireless Power Supply – Principle

“Coreless”
Transformer

Primary coil

Secondary coil/
power receiver



MF-primary
power supply

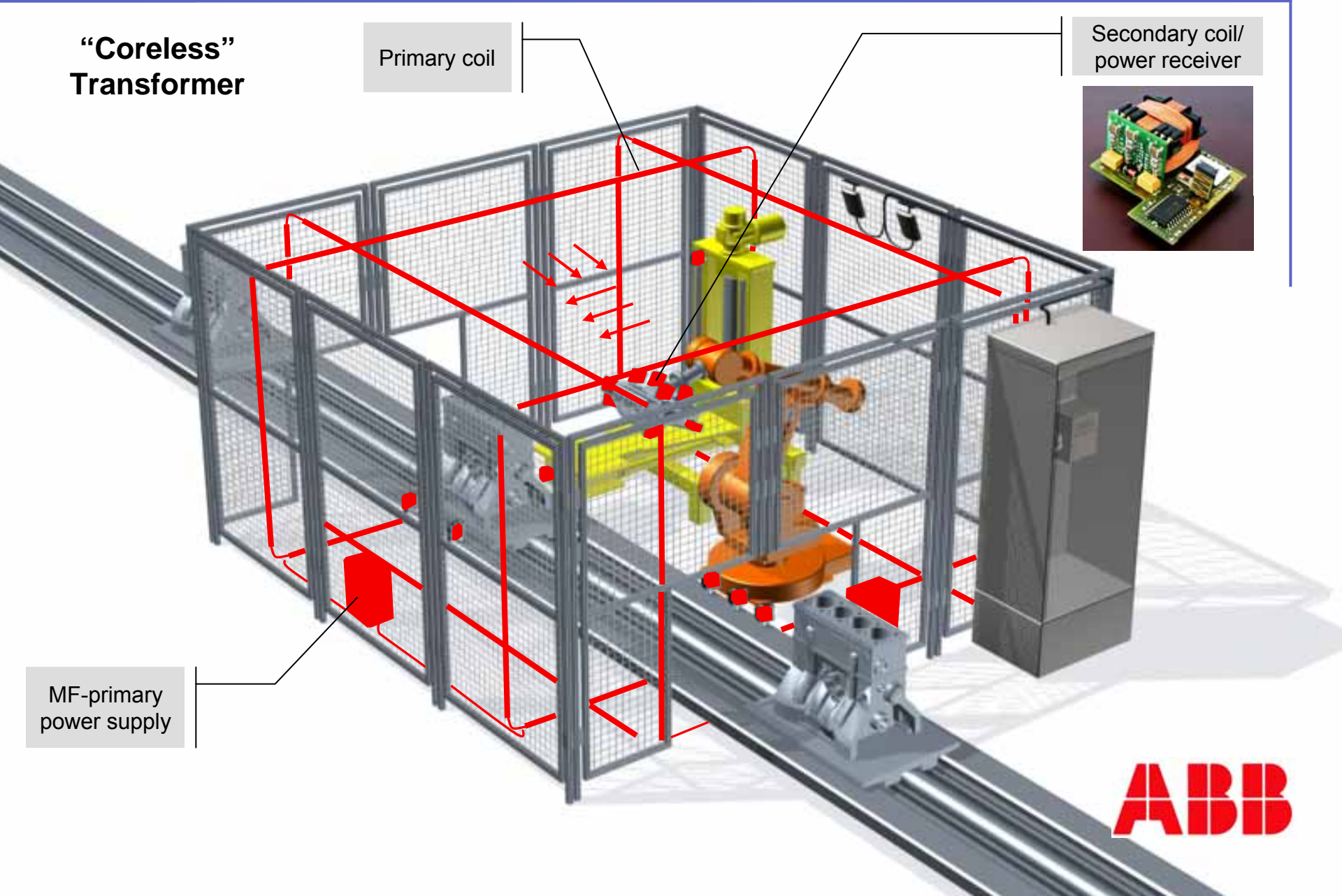

WISA-power: Principle

- High Frequency (HF) - Magnetic field (no radiation)
 - “Bad” Transformer -> Resonant Transfer
 - Un-modulated, magnetic field at 120 kHz, generated by “primary loops”

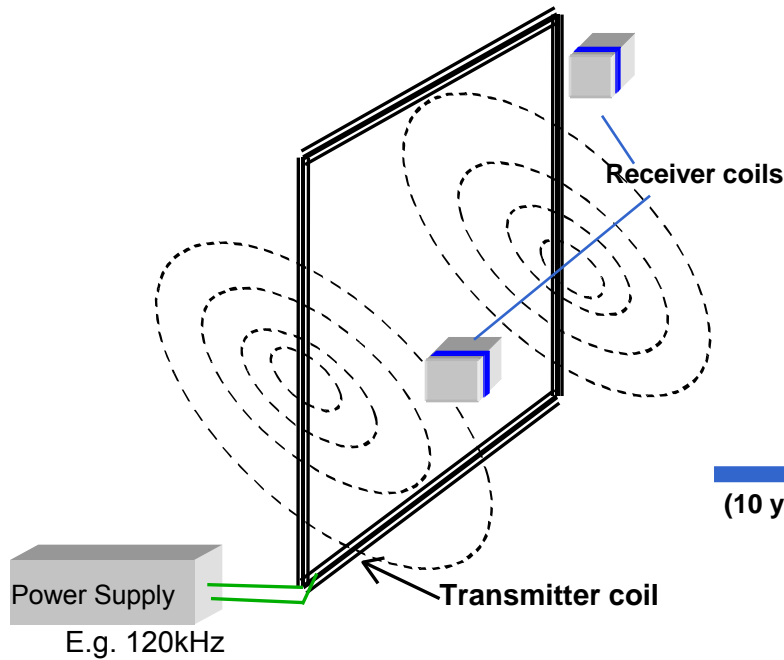

(10 years, 5 A/m) →

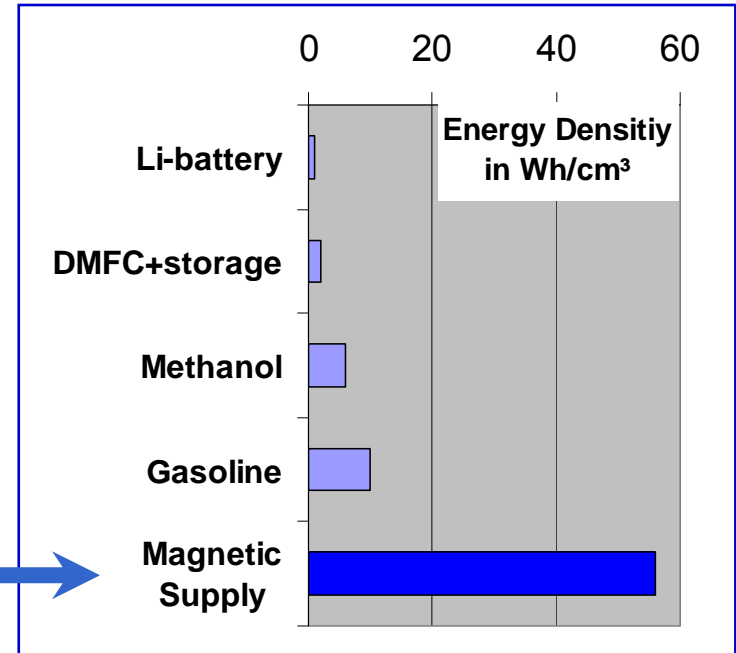

Energy density comparison

➔ Batteries are not an alternative

WISA-Power and Field Strength

WISA-Power energy transmission:

- Un-modulated, magnetic field at 120 kHz, generated by “primary loops”
- Two primary loops ➔ rotating field against shielding/shadowing
- High values only close to loops
- Lowest worldwide recommendations achievable:
 - 13.3 A/m (ICNIRP* recommendation)
 - Public Value: 5A/m (~WPS needs)
 - Pacemaker value 2A/m reached at “coil size distance” to setup/coil
- German occupational limit: 42A/m
- IEEE C.95 limit: 135A/m

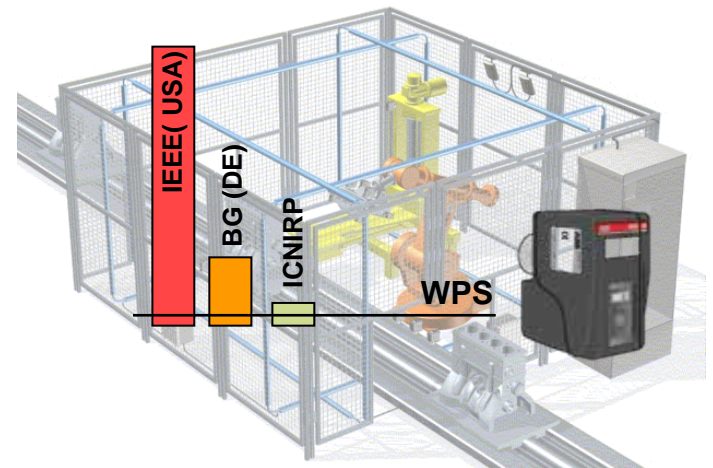
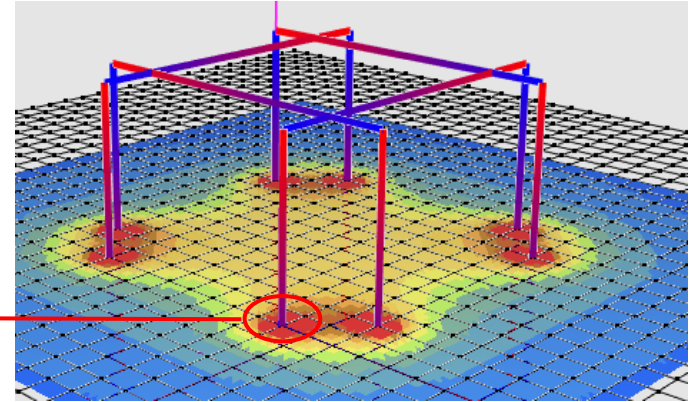

* ICNIRP = International Commission on Non-Ionizing Radiation Protection

Field Distribution Example – 3x3x3 m

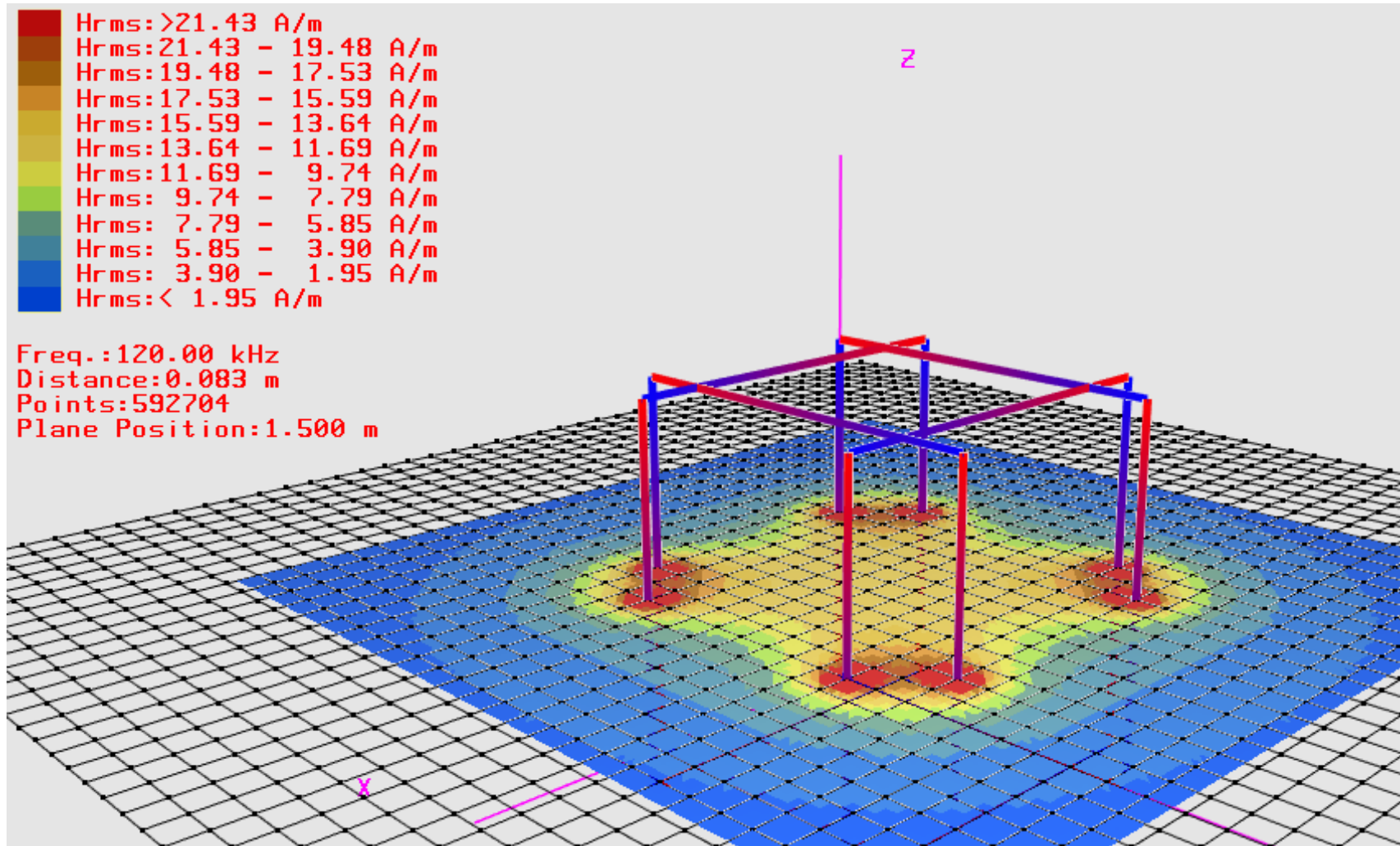

Cell Size and Power Configurations

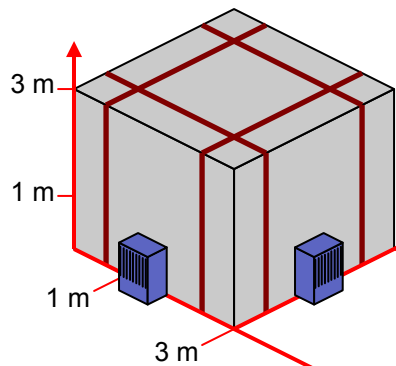

- ➔ 3 x 3 x 3 m³
- 4 Primary loops
- 2 Power supplies

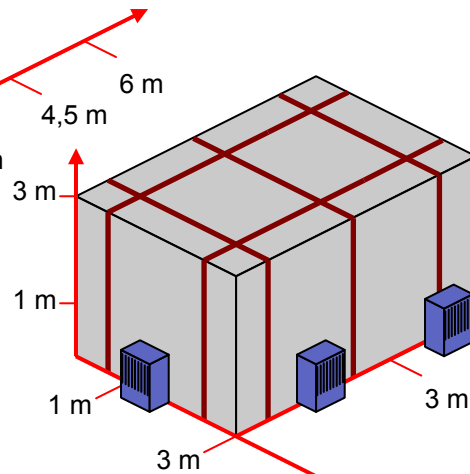

- ➔ 3 x 3 x 4.5 m³
- 5 Primary loops
- 3 Power supplies

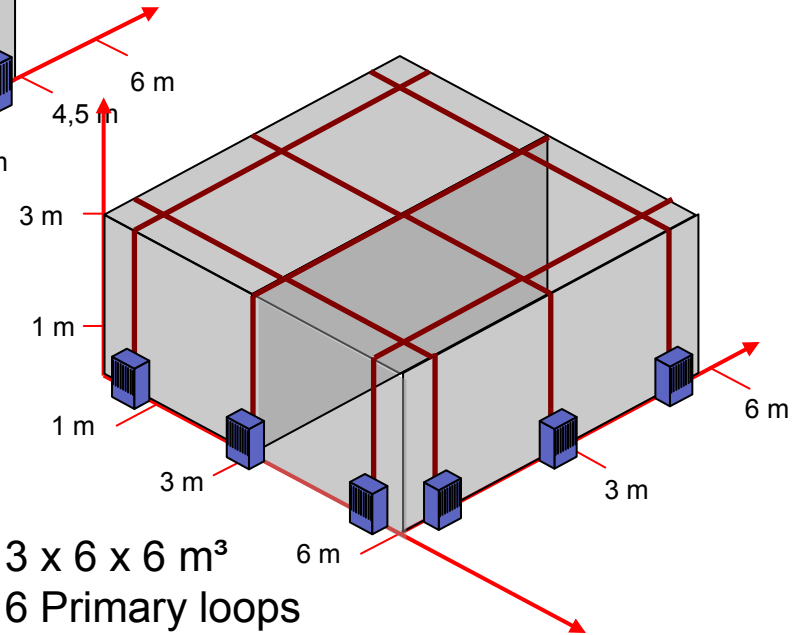

- ➔ 3 x 6 x 6 m³
- 6 Primary loops
- 6 Power supplies

Wireless S/A Networks in the Real World

Technology

Radio circuit

Embedded devices and interfaces to the real world

Harsh environment

- Ideal assumptions
- Radio limits: e.g., speed of frequency / gain / amplitude change; antennas
- Nodes: Filtered inputs, sample rate; slew rate of outputs...
- Gateway: Bus connection limits; adds asynchronous cycle(s) and latency
- Shading, Fading, Coexistence
- Several retransmits have to be possible on different channels within designed real time limit

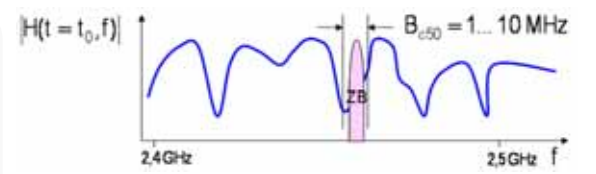
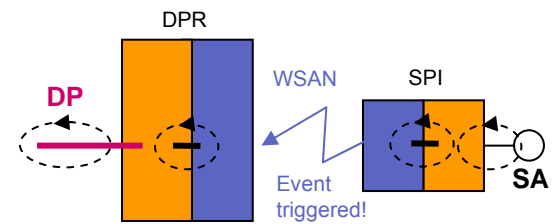
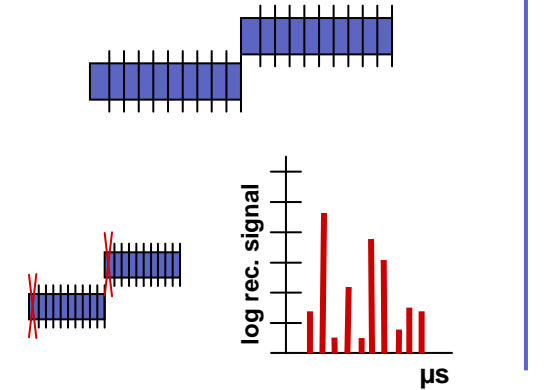

Usable ✓



WISA-COM Implementation Details



Base station

- Specialized RF-front end
 - Operates in full duplex mode
 - Very high isolation between transmission and reception paths
 - Dynamic range > 60 dB
 - High suppression of out-of-band interference
- Controlled by a small μ -controller which maps the wireless links to the addresses of the fieldbus
- Time-critical control of the RF transceiver and baseband signal processing delegated to an FPGA

120



Sensor/Actuators

- WISA nodes are based on standard (IEEE 802.15.1 based) RF transceiver hardware
- A WISA sensor module is comprised of
 - a IEEE 802.15.1 based transceiver
 - microcontroller and FPGA for the WISA protocol
 - antenna with omni-directional radiation characteristics
 - power receiving coil



Extensive Testing and Validation

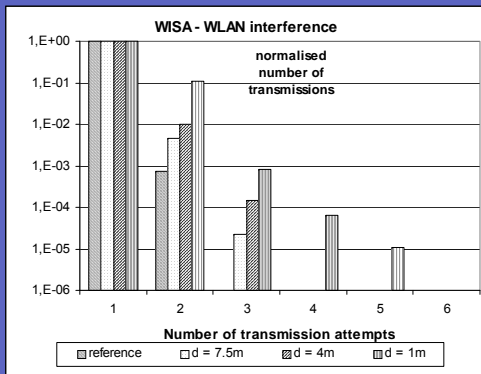

802.11g Interference

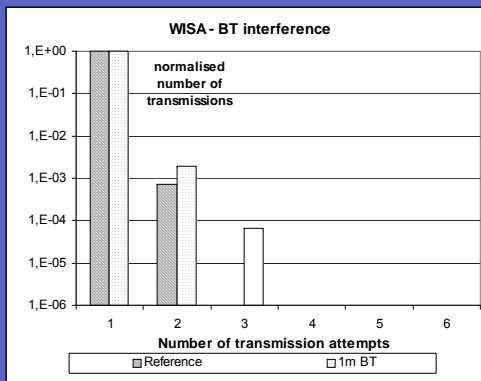

802.15.1 Interference



Stress Tests

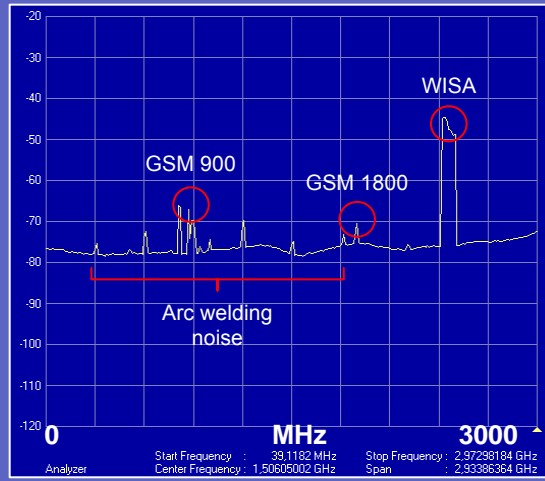

Electromagnetic Interference



Vibration / Shock



Vibration / Shock

WISA Products



WISA: Wireless Interface for Sensors and Actuators





Project leader and production responsible:
Happy and proud!

- 1st Machine: Installed September 2005 (156 WPS, 7 WPU, 4 WDI)
 - Running 24/7 since October 2005
 - Paradigm change: Customer runs machine only with “wireless“
 - End customer contracts “high quality cable“ (with “wireless“)
- 2nd Machine with 80 Sensors running since February 2007





- WISA Sensors in stamping press tooling
(In-die sensing at a leading US-Automotive Manufacturer)

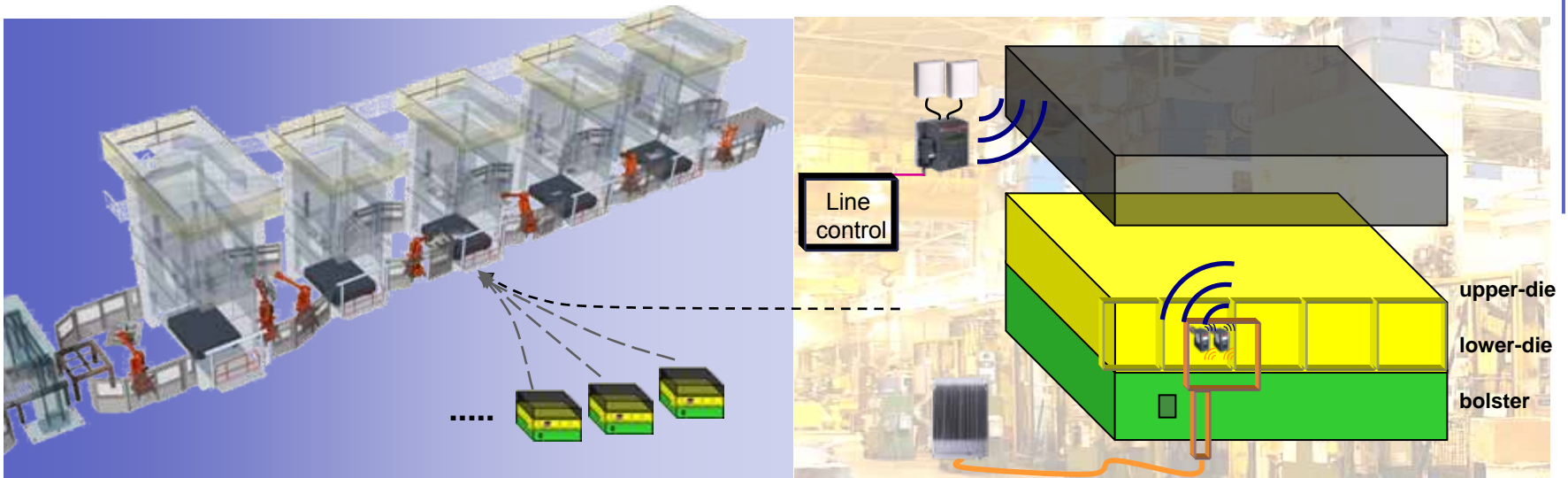

- Several WPS per stamping press tooling, several toolings per press, local WISA-Power supply
- Status: With single press of line (since 09/2005)
Full line in production (since 12/2007)
- Multi-million \$ trust in WISA (tooling worth)
Real time: No single bit outside 30ms timeframe
- Benefit: Increased productivity - payback within few months

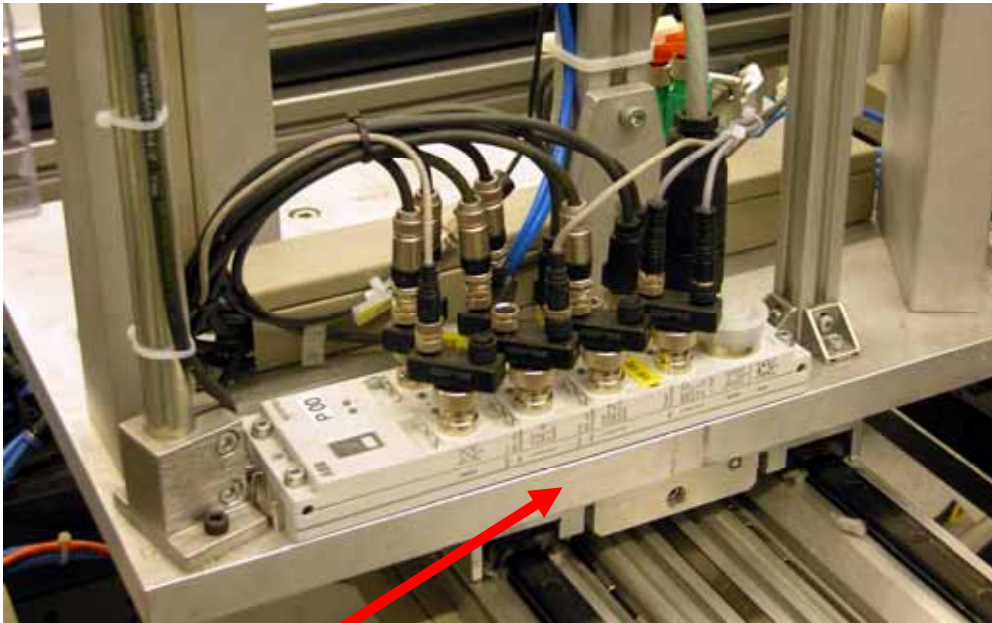

- Signal cabling to sensors on moving slide caused frequent downtime
- Wireless Solution
 - Signal transmission without wiring
 - Retrofit of existing sensors
 - Easy expansion (Adding new sensors)
- Status
 - A second cell will be retrofitted wireless I/O pads
 - Wireless prescribed as a standard solution for future cells



Aluminum Foundry Automation

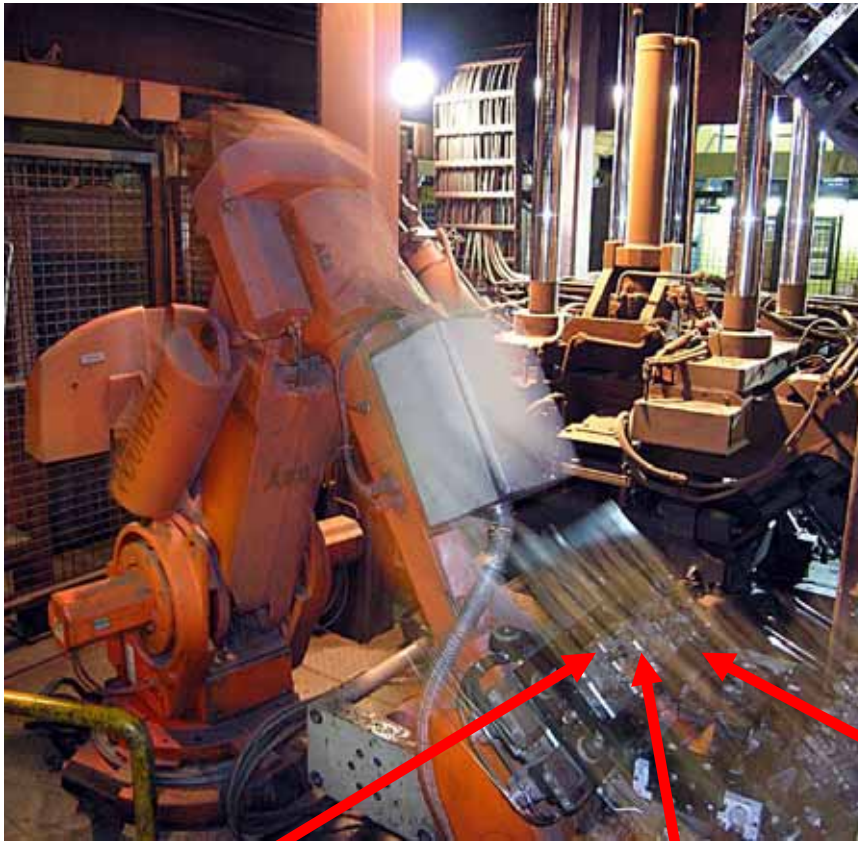

- Connector failure due to frequent tool changing
 - Three tool changes per production cycle
 - Cycle time ~15 s
- Wireless Solution
 - Wireless signal transmission
 - Redundant power supply cabling
- Status
 - New cells are now only equipped with WISA



~15s





Pneumatic Valve terminal* from FESTO (demonstration unit)

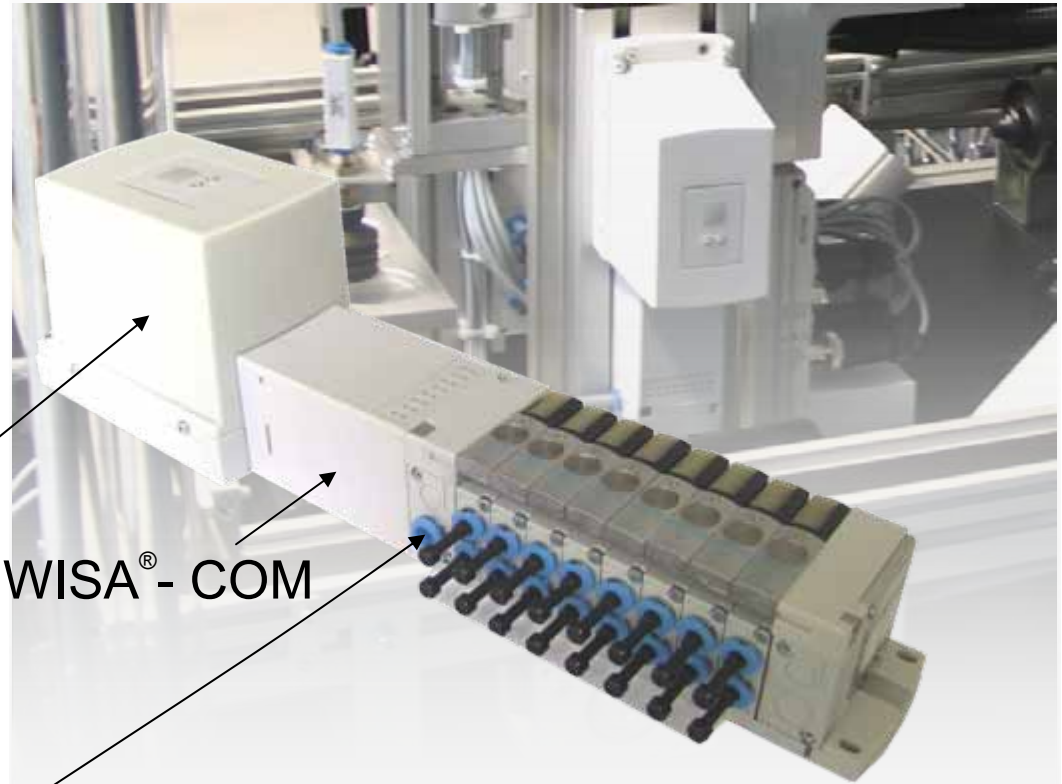

- with WISA[®]-POWER and WISA[®]-COM
- Fully wireless
- No cables anymore
- Needs only one air tube

* Pneumatic valves are the most widespread electrical actuator in discrete factory automation

Trends / Drivers

- Co-existence
 - As deployment of wireless systems increases, so does the need for co-existence measures
 - ➔ Growing need to avoid/reserve frequency bands for other systems
 - Dynamic vs. static
 - UL / DL blacklisting
 - Trade-off with performance

- Low Power Radio Developments
 - Improvements on power consumption (architecture and base components)
 - ➔ Adds margins to the power budget of WSN nodes
 - Enables use of smaller secondary coils
 - Enables larger cells to be covered
 - Enables wireless actuators
 - Enables lower field strengths

Interference!

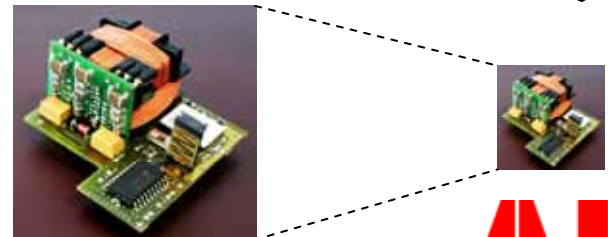
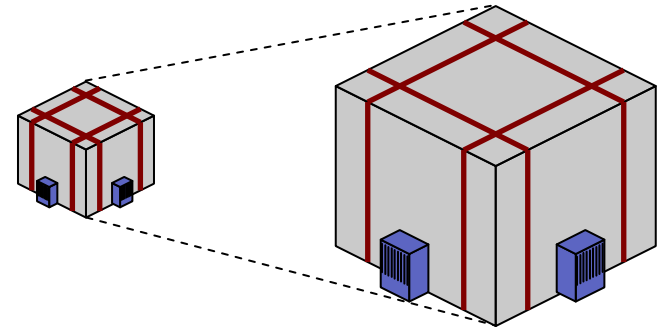
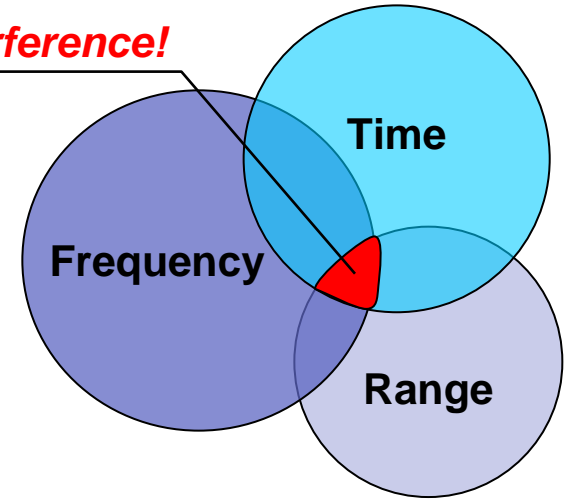

Trends / Drivers

- Wide spread adoption of WSA is hindered by lack of standards to govern
 - Interoperability
 - Conformance/compliance
 - Co-existence

- WSA standardization active in Process Automation
 - *WirelessHART*® first industrial standard released in 2007
 - IEC 65C/507A/PAS (*WirelessHART*®) ballot ongoing
 - ISA100 (draft specification)
 - Fieldbus Organizations refer to either *WirelessHART* and/or ISA100

- Working groups on WSA in Factory Automation being established
 - ISA100 work group
 - PNO WSA work group
 - IEC discussions

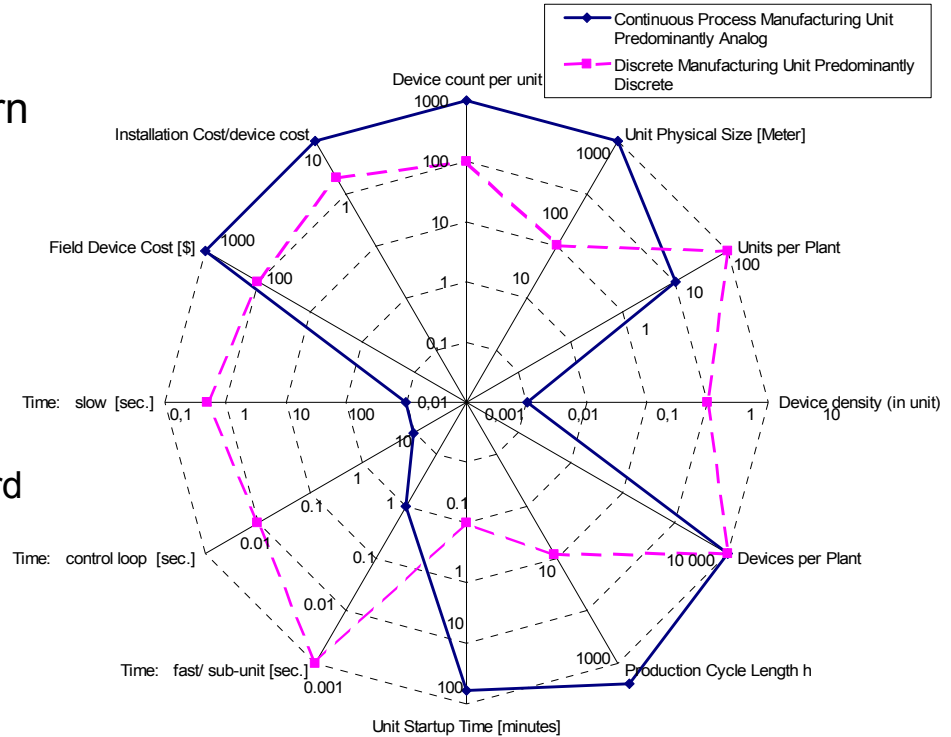

**Same-Same
but *Different***





Power and productivity
for a better world™