

**PLCopen:**  
  
**changing the world  
of industrial automation**  
  
**with Motion Control 2.0**

**Eelco van der Wal**  
**Managing Director PLCopen**



**IEC 61131-3**



**Harmonizing the way people look to  
control**

**and PLCopen extends this basis**

# PLCopen Motion Control :



**The merge of  
Logic and Motion**

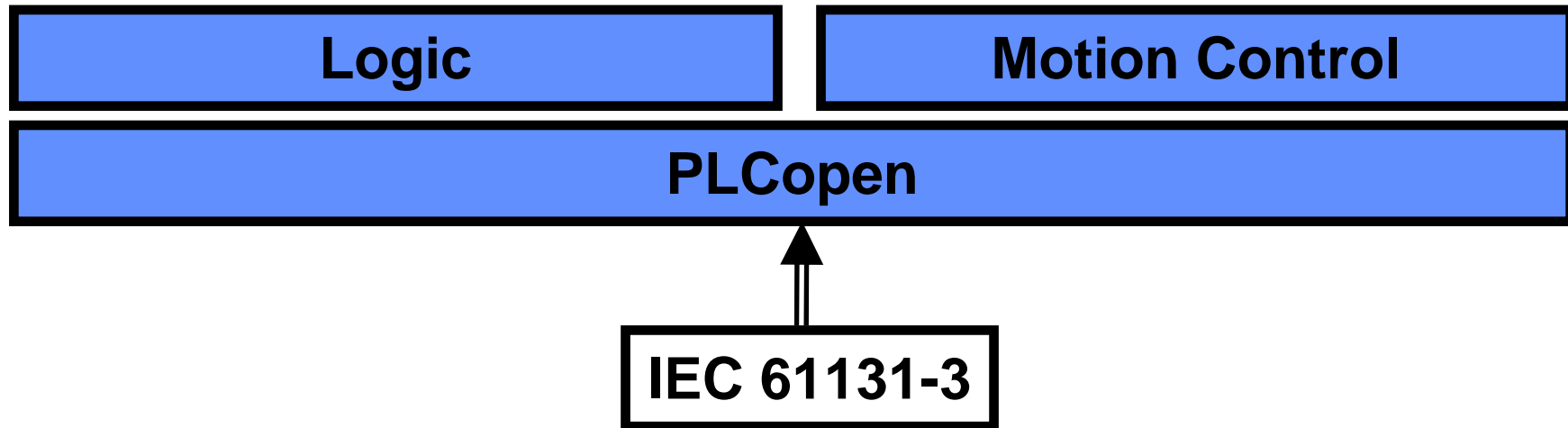

# The next step: Adding Safety (at machine level)

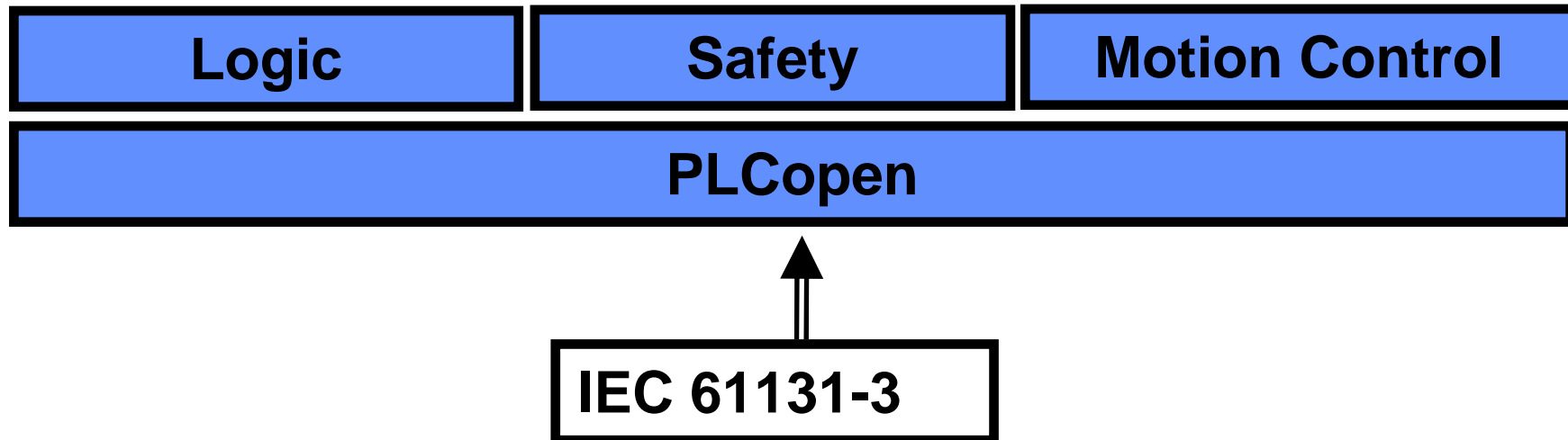

# PLCopen

## Combining Logic, Motion and Safety

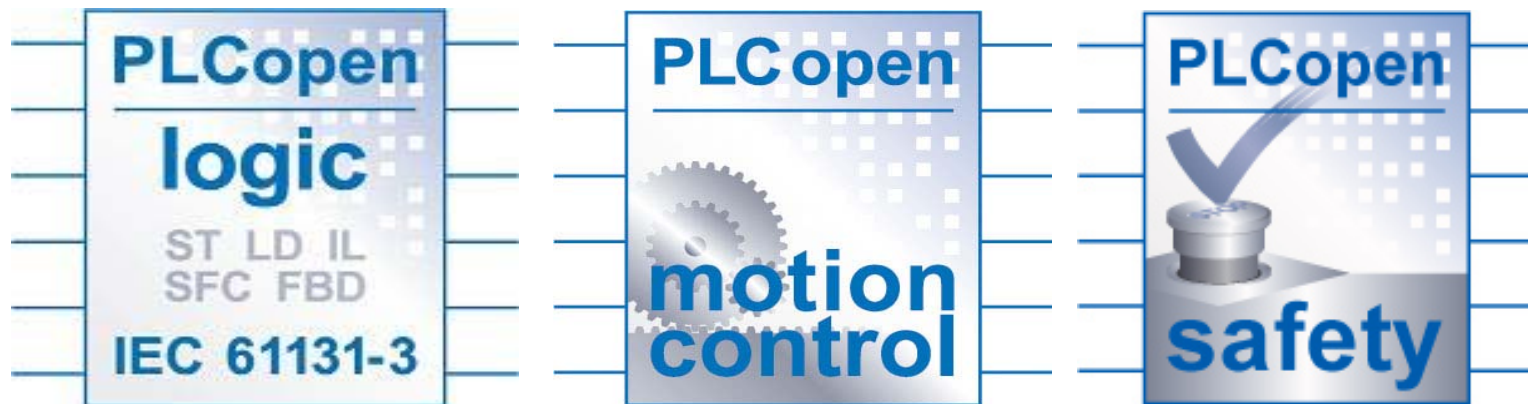

**Providing Structuring, Decomposition,  
Reuse and less training**

## Percentage of Software development costs in production systems (source: McKinsey)

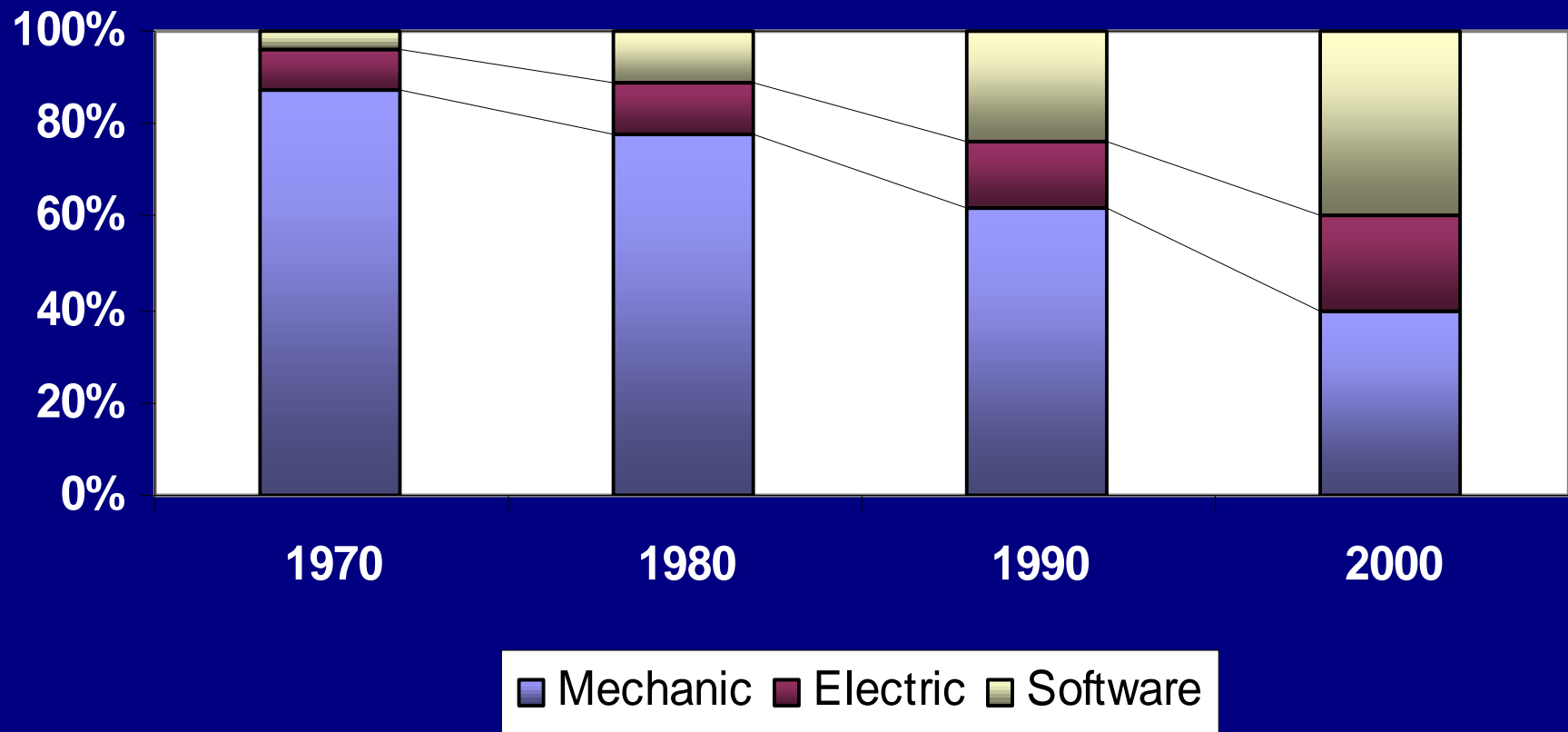

# Managing Complexity

**100 – 10,000 – 1mio – 100mio Lines of Code**

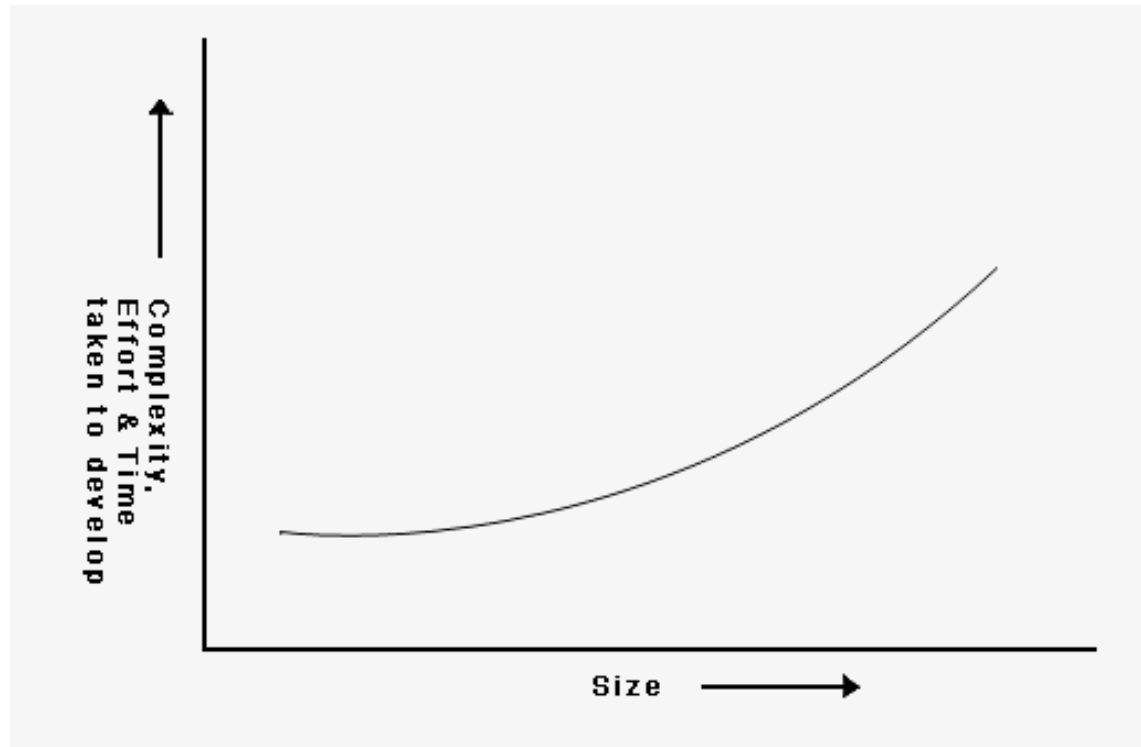

# A hierarchy of abstraction

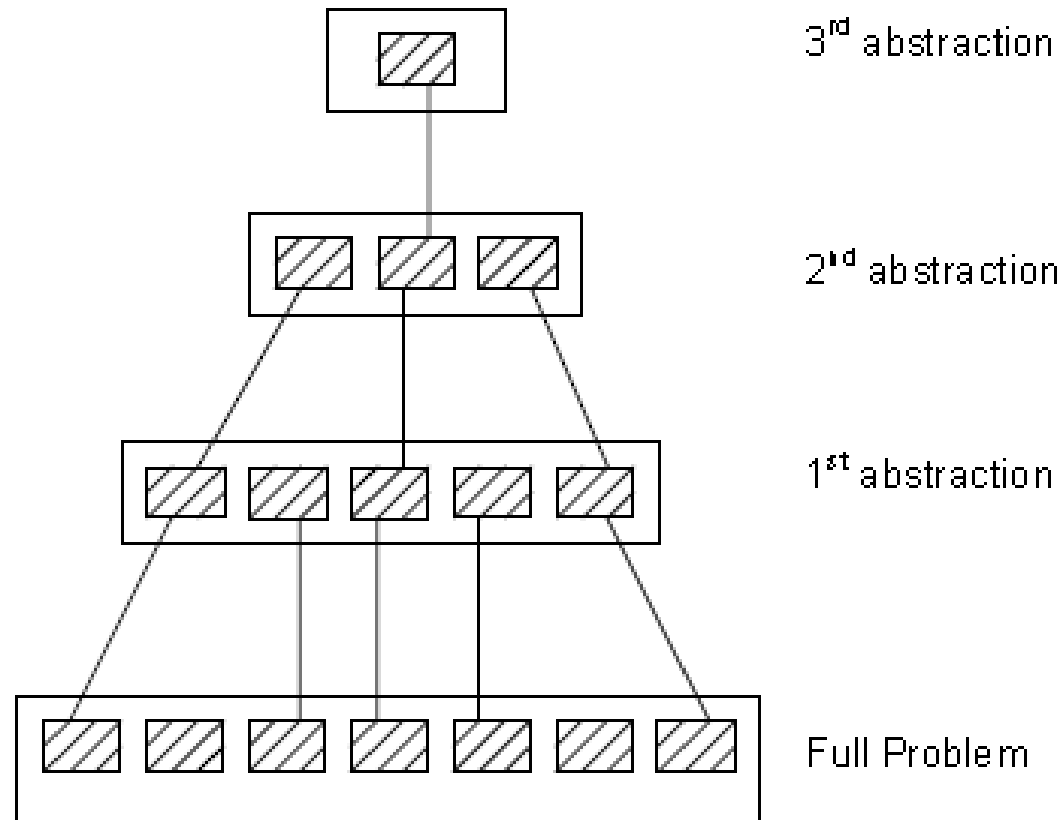

# Decomposition and Reuse

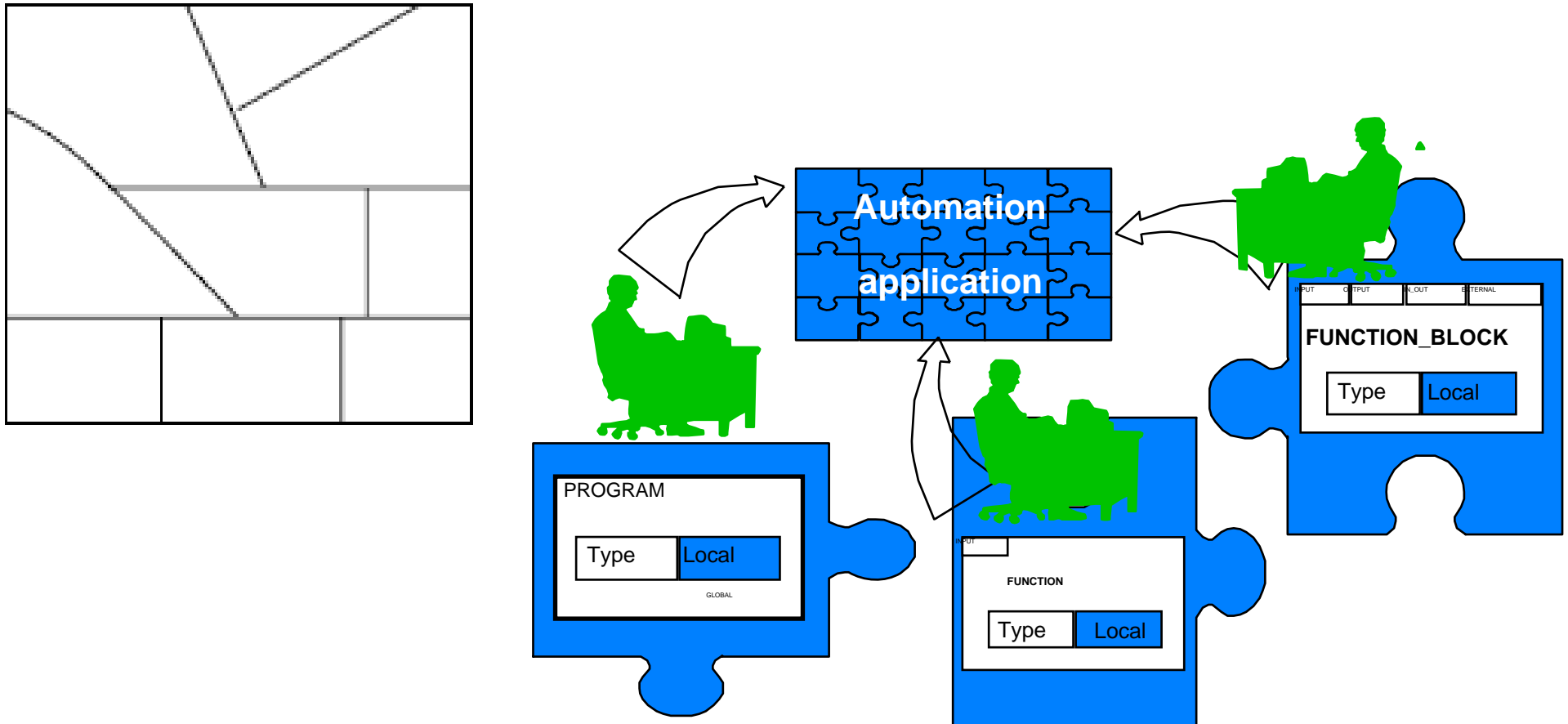

# Abstraction via Function Blocks

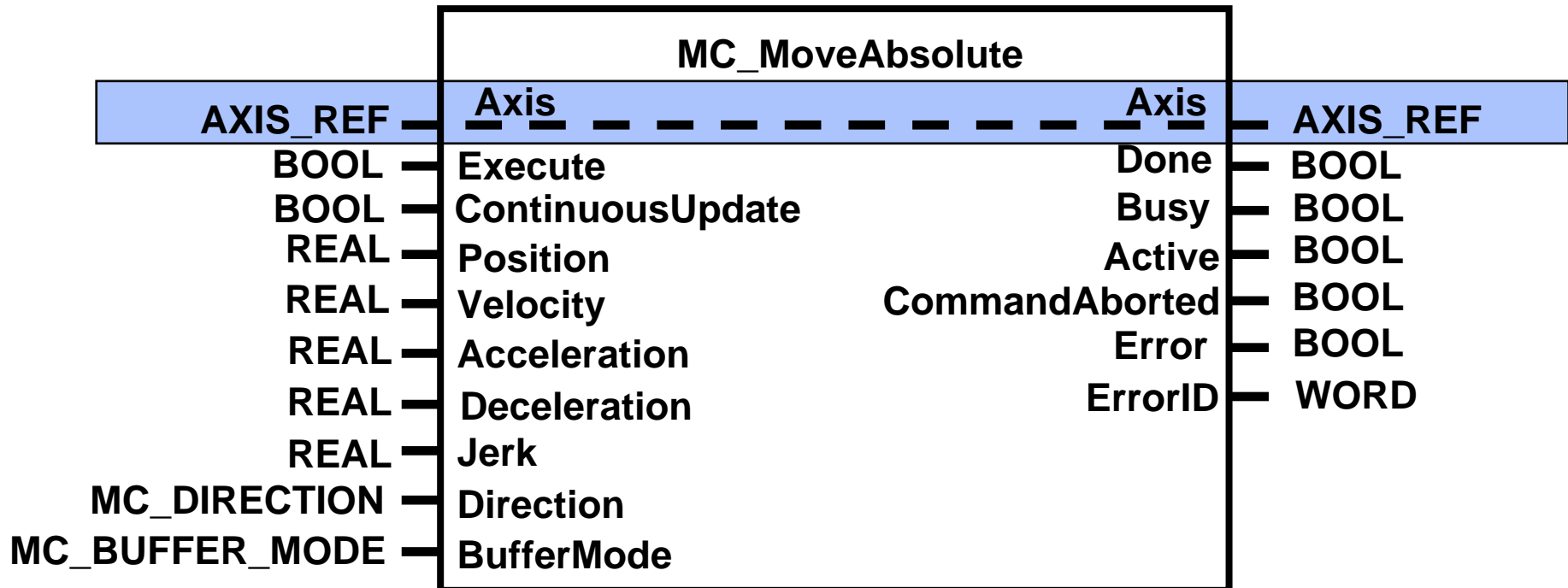

# Axis\_Ref with 1 FB

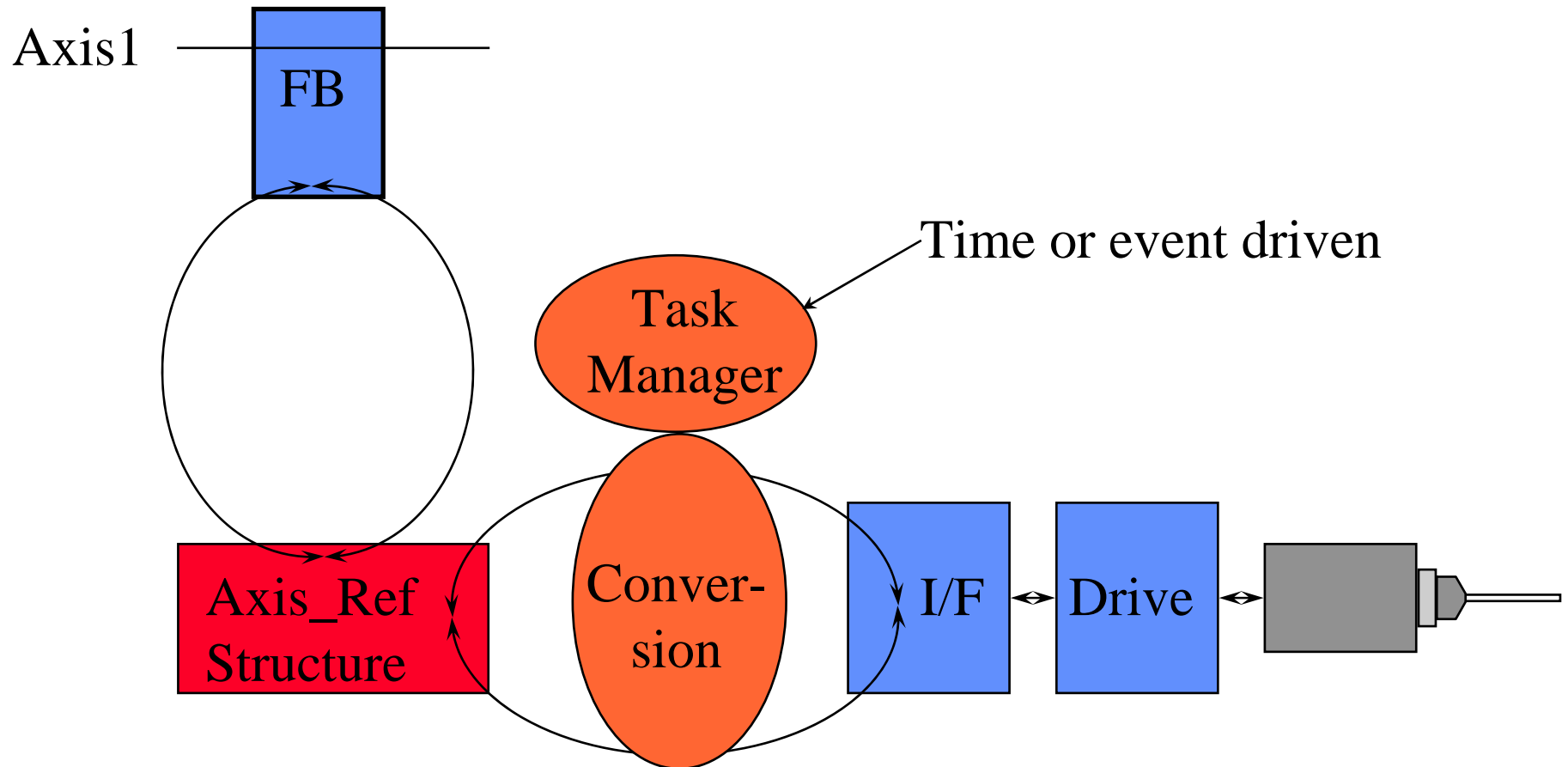

# Axis\_Ref with 2 FBs

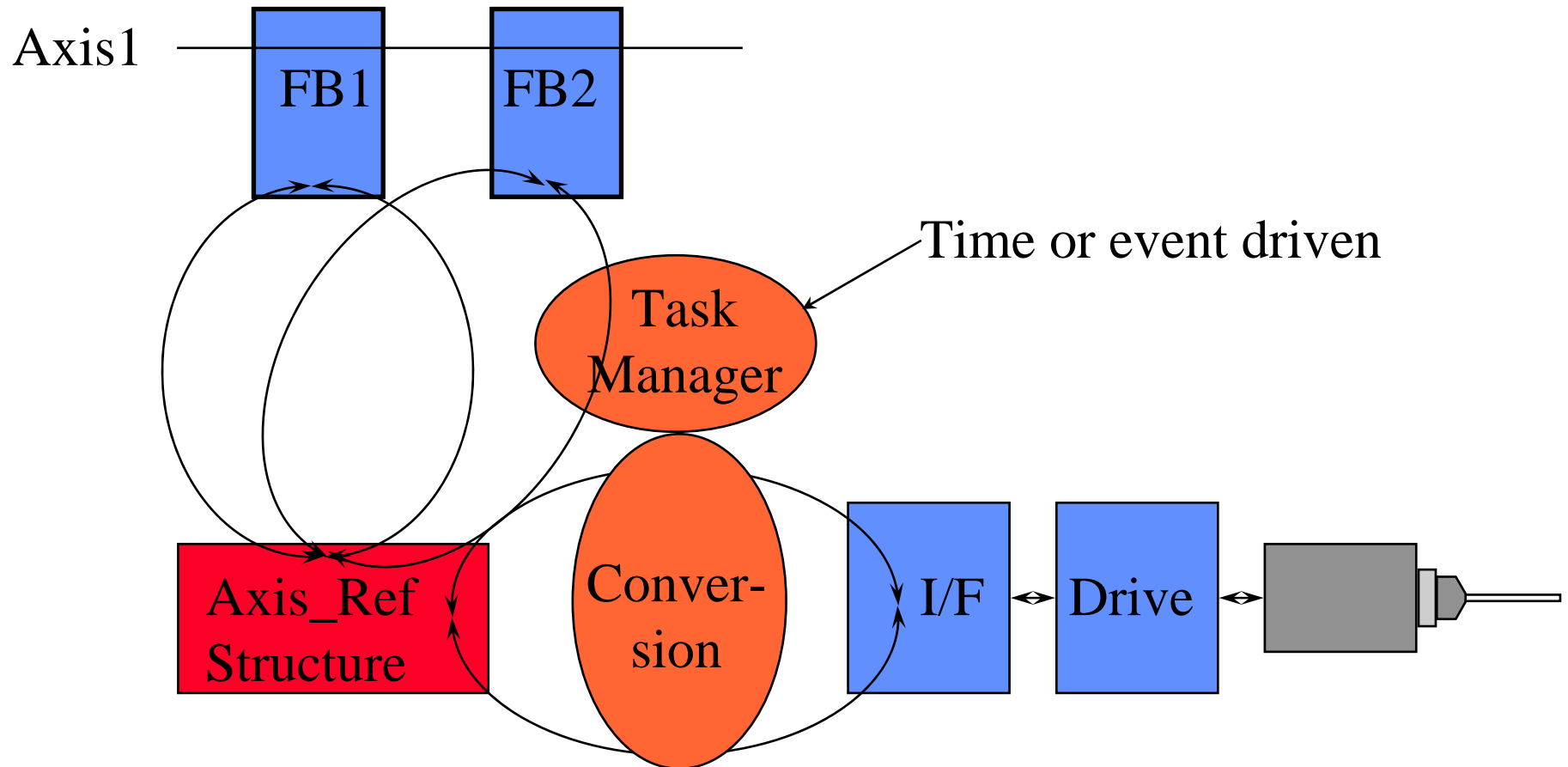

# Encapsulation: Webcutting

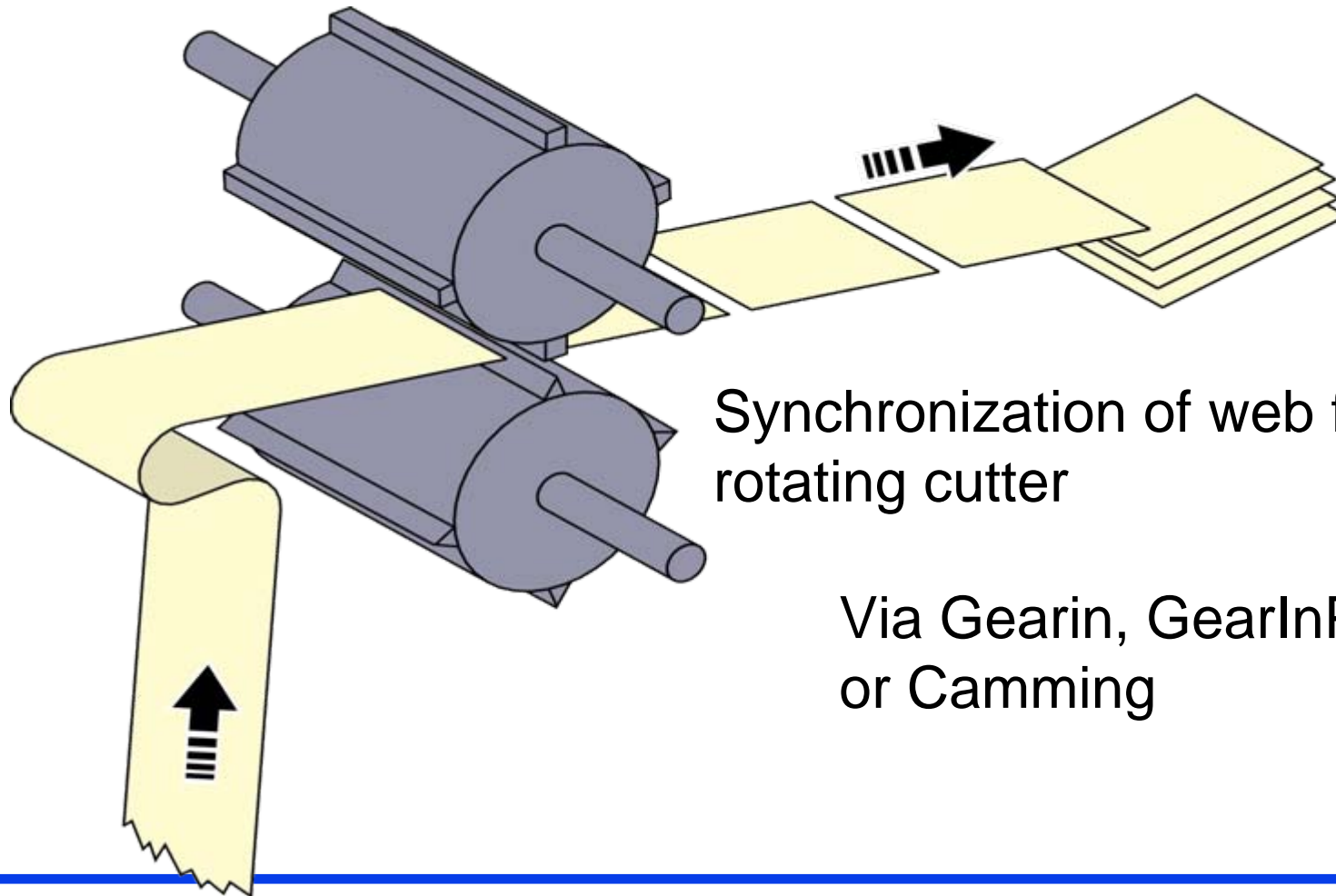

Synchronization of web feeding & rotating cutter

Via Gearin, GearInPosition or Camming

# Mechatronic solutions

**Mechanical  
solution.**

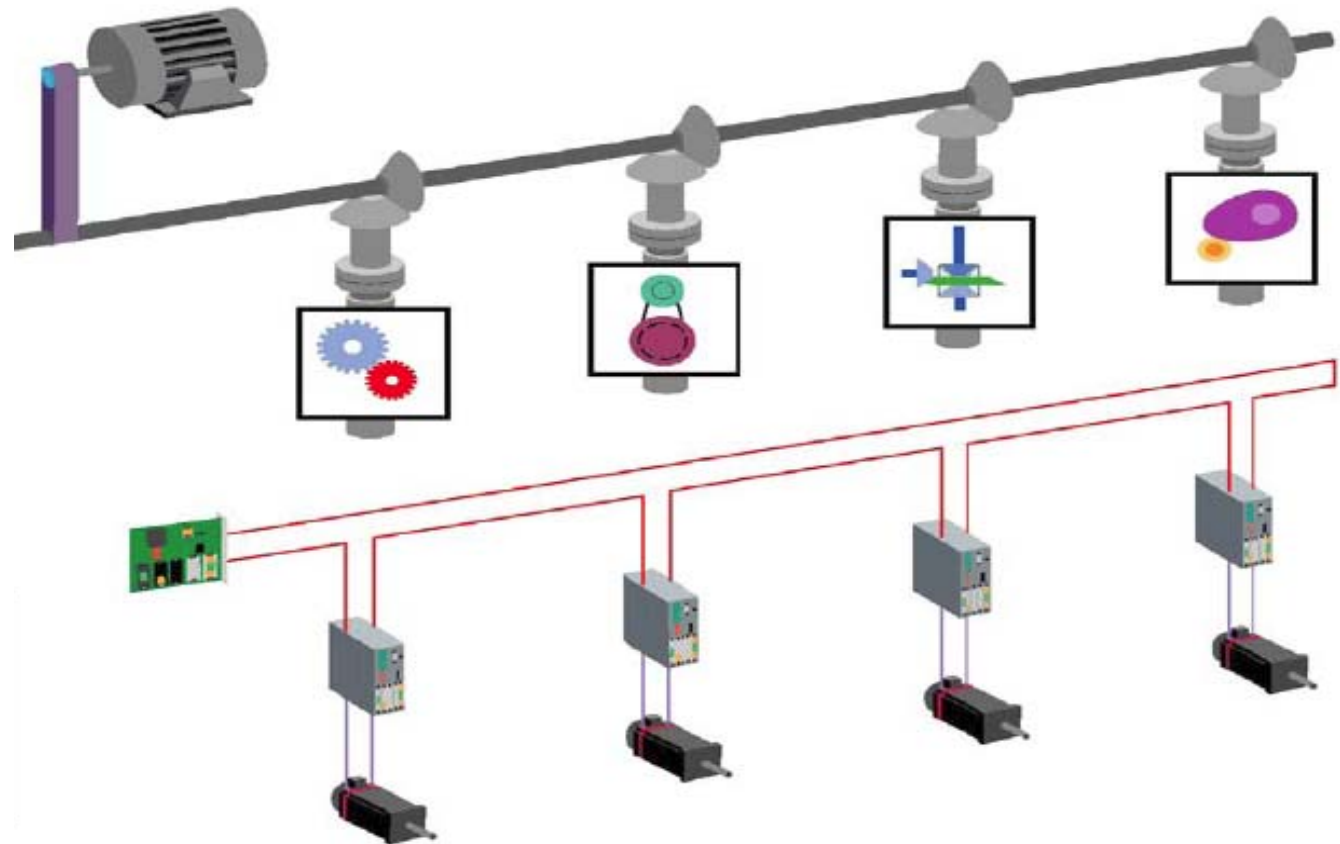

**Control  
solution**

## **Time-to-Market**

**via flexibility in equipment and process**

## **Asset utilization**

**minimal finished good inventory**

## **Flexibility in Manufacturing**

**process followed by packaging to provide end product**

## **Overall Equipment Efficiency OEE**



## The integration of Part 1 and Part 2

# Status PLCopen Motion Control

- **Part 1 – FBs, V. 1.0 - 2001, V. 1.1 - 2005**
- **Part 2 – Extensions (2005)**
- **Part 3 – User Guidelines (2008)**
- **Part 4 – Coordinated Motion (2008)**
- **Part 5 – Homing procedures (2011)**
- **Part 6 – Fluid Power (2011)**



# Planned PLCopen Motion Control Releases

- **Merge of Part 1 and Part 2 – Motion Control 2.0**
- **Release of Part 5 – Homing**
- **Update of Part 3 – User Guidelines**
- **Part 6 – Extension for Fluid Power**

## Status PLCopen Motion Control

- **Over 27 companies certified with over 36 products**
- **check website for overview and full list**



# PLCopen Motion Control 2.0

- **Consistent naming conventions and definitions**
- **Input 'Continuous Update'**
- **New FB CombineAxes,**
- **Representation of the State Diagram**
- **New input MasterValueSource**
- **New FBs ReadMotionState and ReadAxisInfo**
- **Split of Phasing and MoveContinuous FBs in to both relative and absolute versions**
- **Clearer specified behavior of the output Active**

# Input Continuous Update: Winding / Unwinding

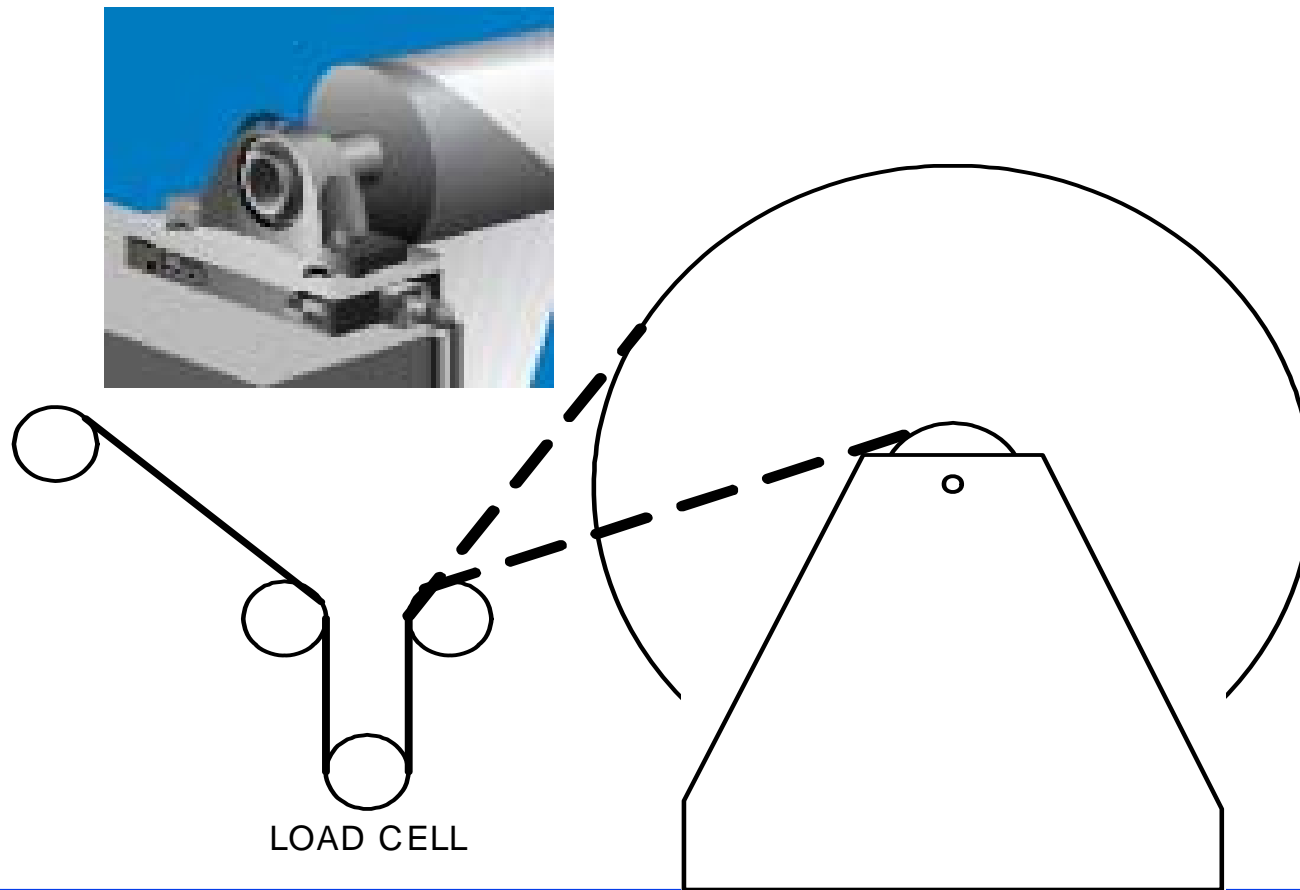

## 2-cycle approach with Execute

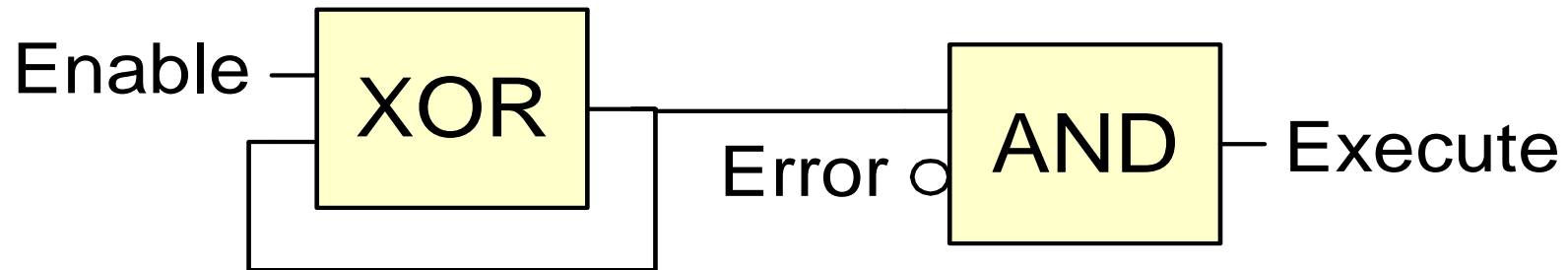

In1	In2	Out
T	F	T
T	T	F
T	F	T

# Input Continuous Update

- **With Continuous Update set, the inputs are used every cycle**
- **With Continuous Update not connected or not set – no change in behavior**
- **Benefits in fast scaling movements and in dynamic behavior**

## Combine Axes

- **A new Function Block CombineAxes, combining the motion of 2 axes into a 3rd axis with selectable combination method. Basically it is a calculation of a new position setpoint based on the 2 position setpoints of the input axes.**

# Example Combine Axes

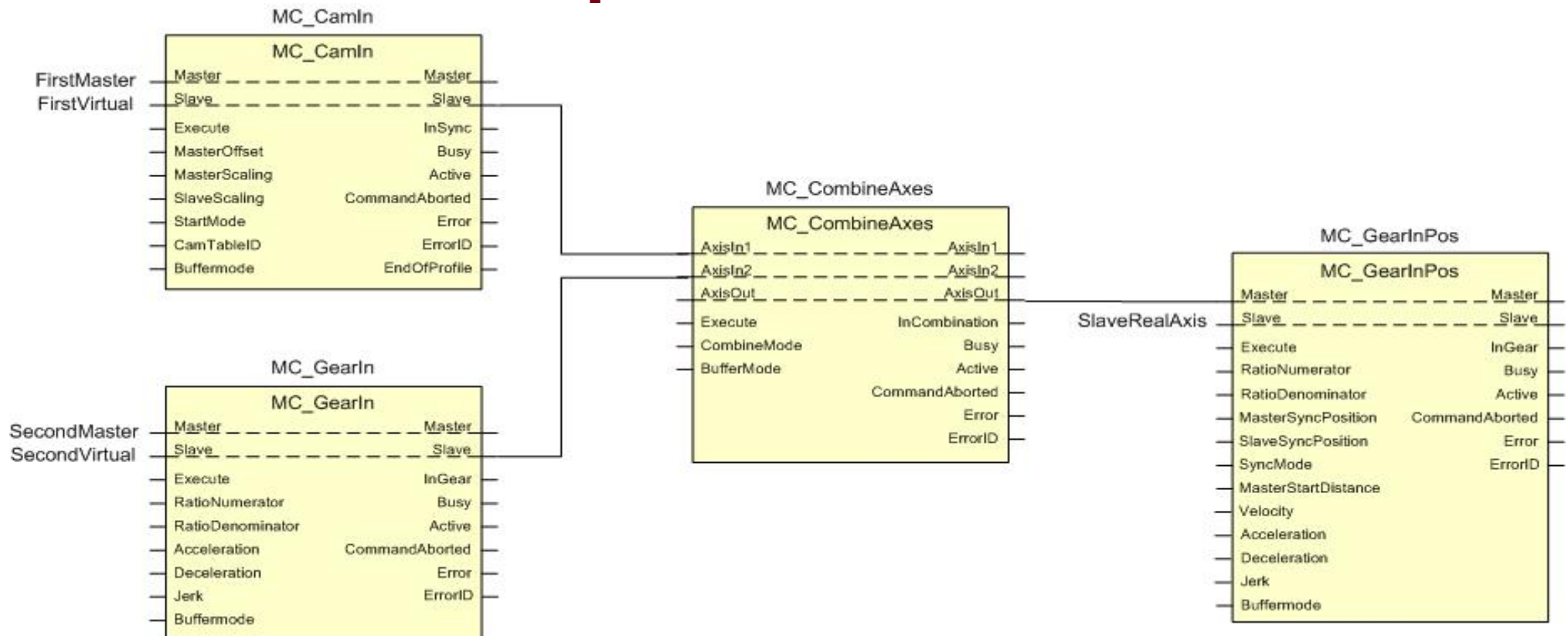

# Representation State Diagram PLCopen *for efficiency in automation*

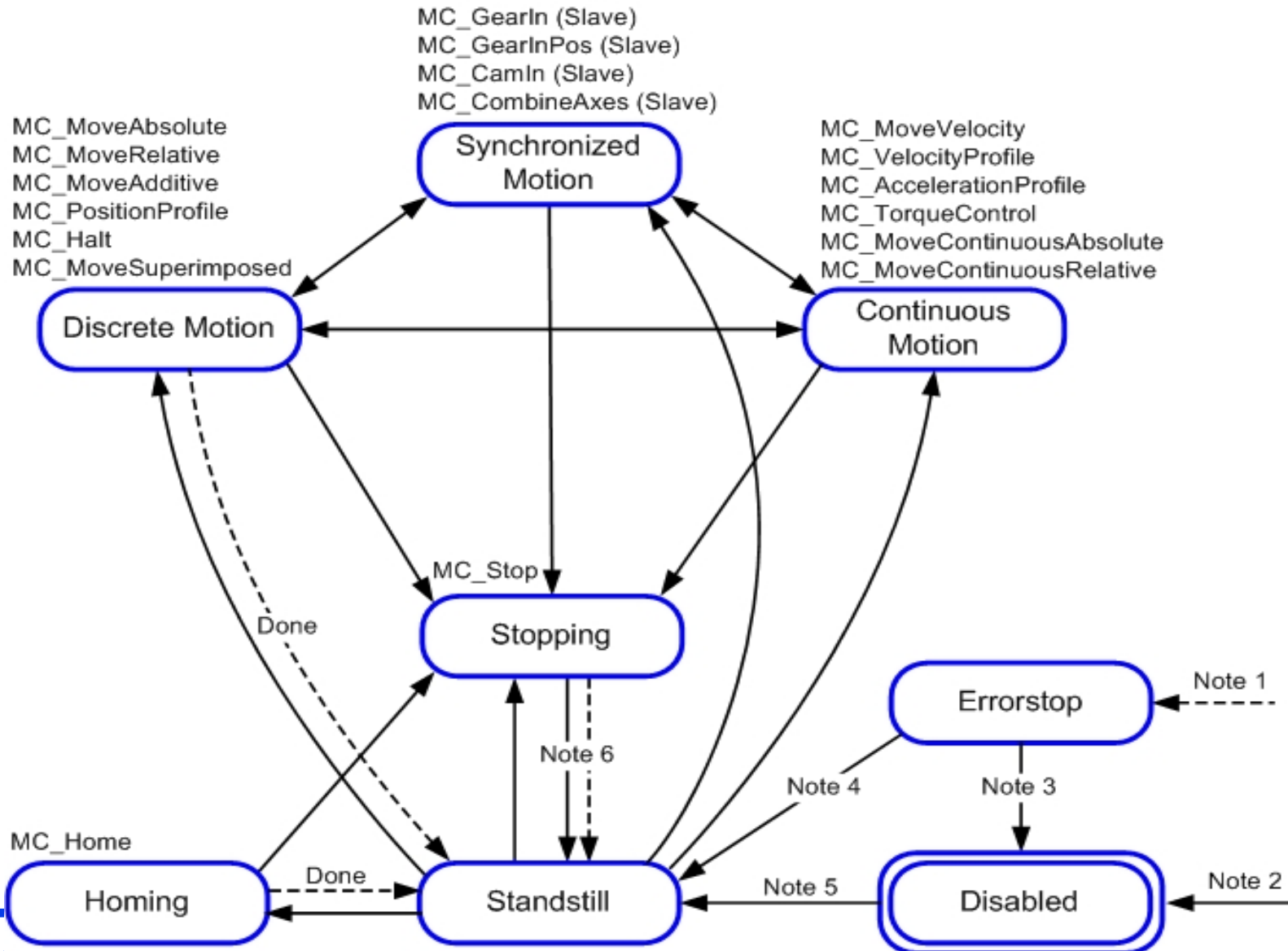

# Input MasterValueSource

- **Defines the source for synchronization:**
  - mcSetValue - Synchronization on master set value
  - mcActualValue - Synchronization on master actual value
  
- **Relevant for MC\_CamIn, MC\_GearIn, MC\_GearInPos, MC\_ReadMotionState, and MC\_CombineAxes**

**More Information...  
and to download the specifications**

**[www.plcopen.org](http://www.plcopen.org)**

**Free-of-Charge electronic Newsletter 'PLCopening' (in English)**

**email: [evdwal@plcopen.org](mailto:evdwal@plcopen.org)**

# Thanks

