

PLCopen:

changing the world of industrial automation

Overview of the current activities and working groups

Eelco van der Wal
Managing Director PLCopen

PLCopen tagline

PLCopen
for efficiency in automation

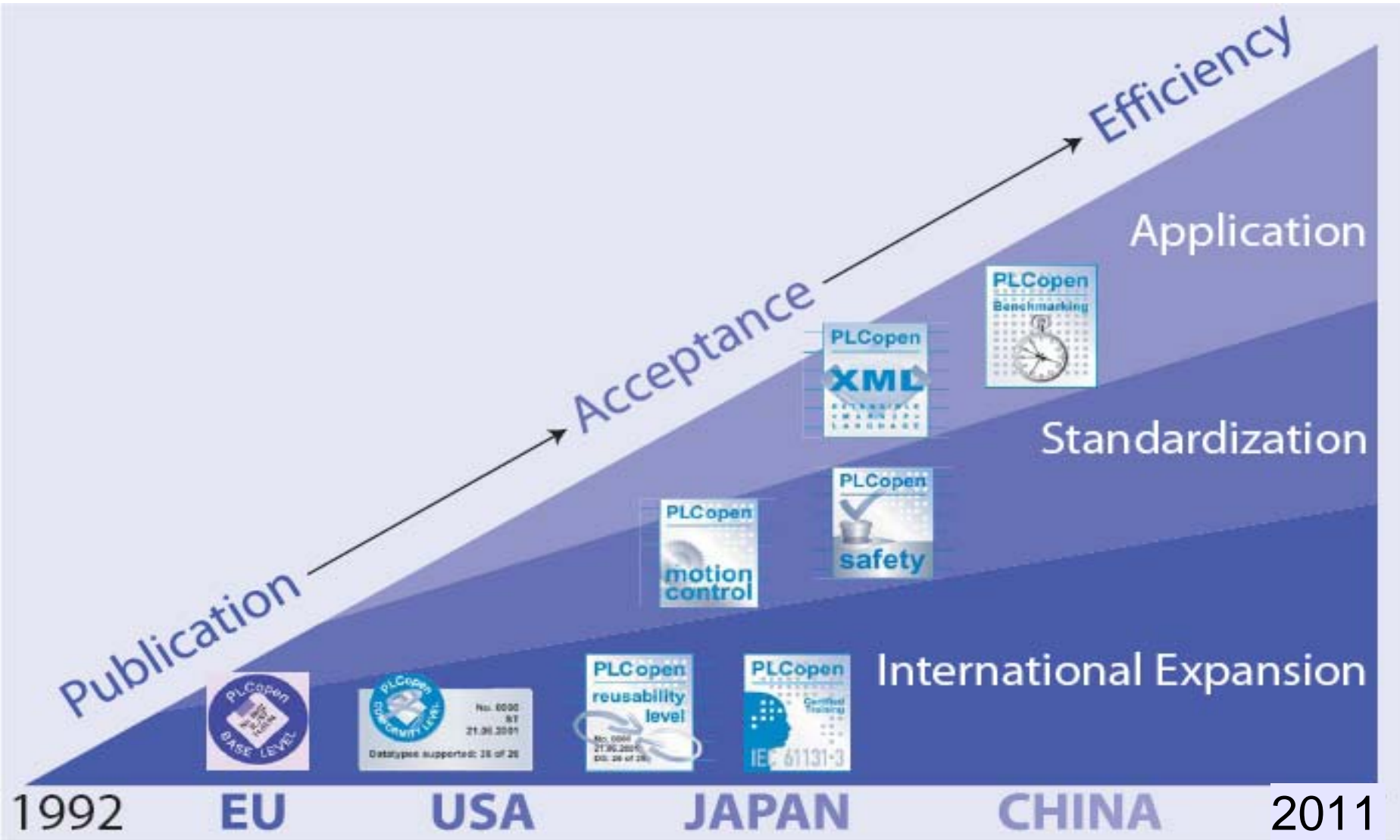

Organization



General Meeting, BOM, MD

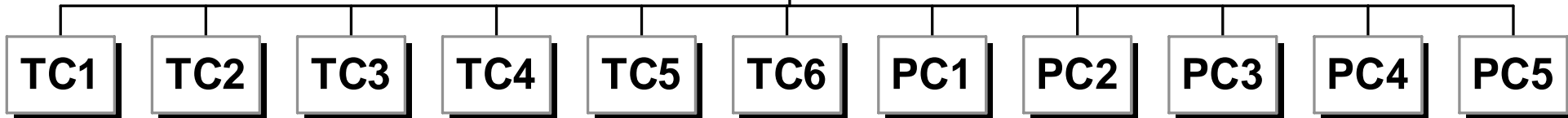

TECHNICAL

PROMOTIONAL

COMMITTEES





TC1 Standards: the basis



IEC 61131-3

Harmonizing the way people look to control



IEC 61131-3

**Harmonizing the way people look to
control**

and PLCopen extends this basis

TC2

Functions and Function Blocks

-

**Harmonization of libraries
of reusable components**

-

Example: Motion Control

PLCopen Motion Control :



**The merge of
Logic and Motion**

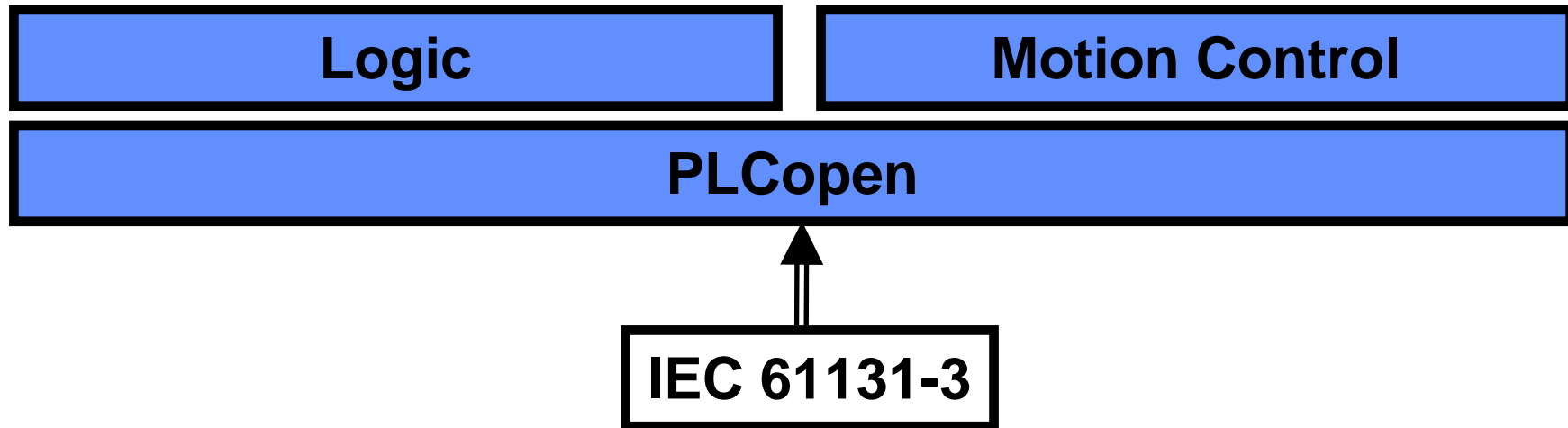
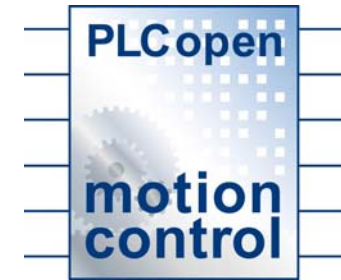

Status PLCopen Motion Control

- Part 1 – Function Blocks for Motion Control
- Part 2 – Extensions
- Part 3 – User Guidelines
- Part 4 – Coordinated Motion
- Part 5 – Homing procedures
- Part 6 – Fluid Power
- Over 27 companies certified with over 600 products (check website for full list)



Current PLCopen Motion Control Releases

- **Merge of Part 1 and Part 2 – Motion Control 2.0**
- **Release of Part 5 – Homing**
- **Update of Part 3 – User Guidelines**
- **Part 6 – Extension for Fluid Power**

**The next step:
Adding Safety (TC5)
(at machine level)**

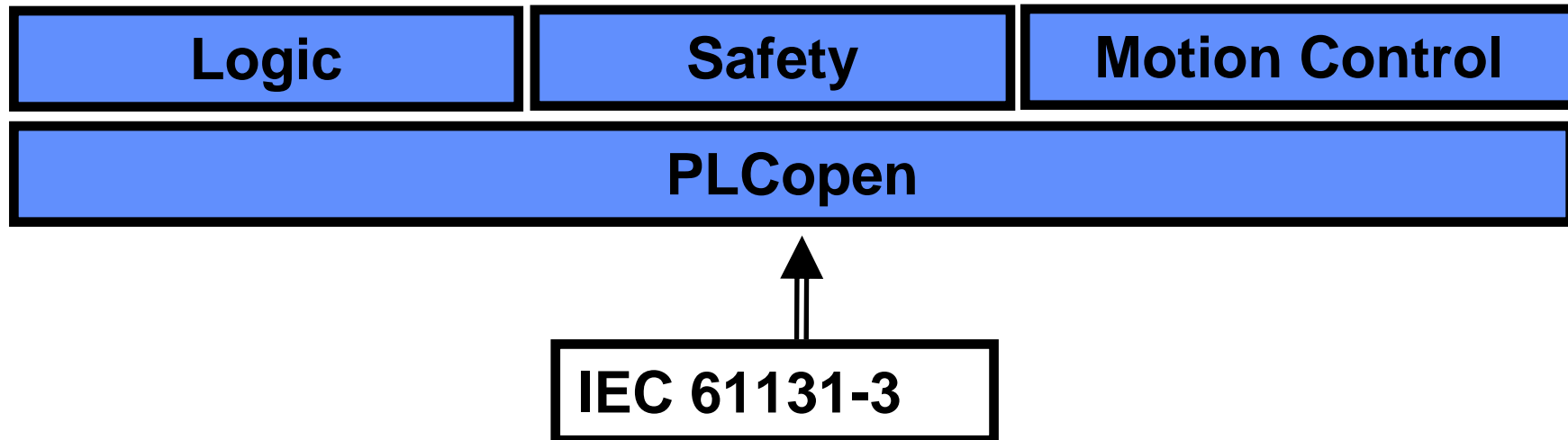

Reasons to merge – a changing environment

- **Too many dialects, too many standards, including IEC 61508 and IEC 62061;**
- **Additional governmental requirements increasing the liability issues;**
- **No independent training material**
- **Trend to software solutions**
- **Too much done by machine builder**
- **Growing market expected**

Reasons to merge – a changing environment

- **The tendency to move from one motor (master axis) to multiple axes, driven by mechatronic solutions;**
- **The availability and acceptance of digital networks with safety functionality built-in;**
- **The inherent move from hardwired safety functionalities to software solutions;**
- **The increasing importance of safety related issues regarding personnel and machines.**

TC5 - Safety : New initiative

- Focused to material presses used for metal forming
- Extensions for Presses will be published as Part 5

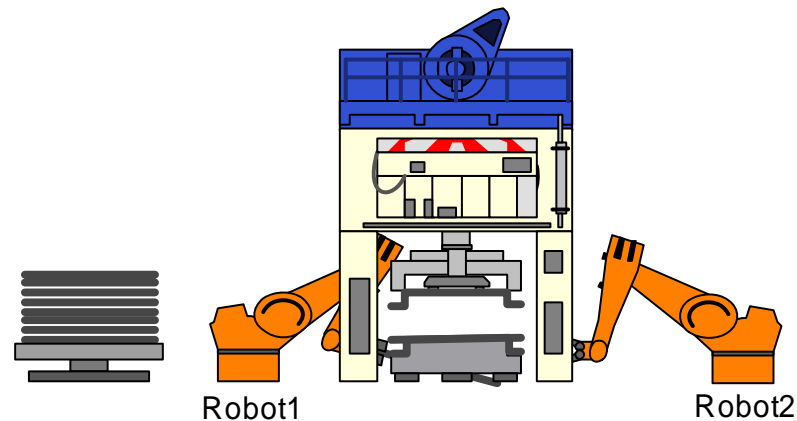

PLCopen

Combining Logic, Motion and Safety

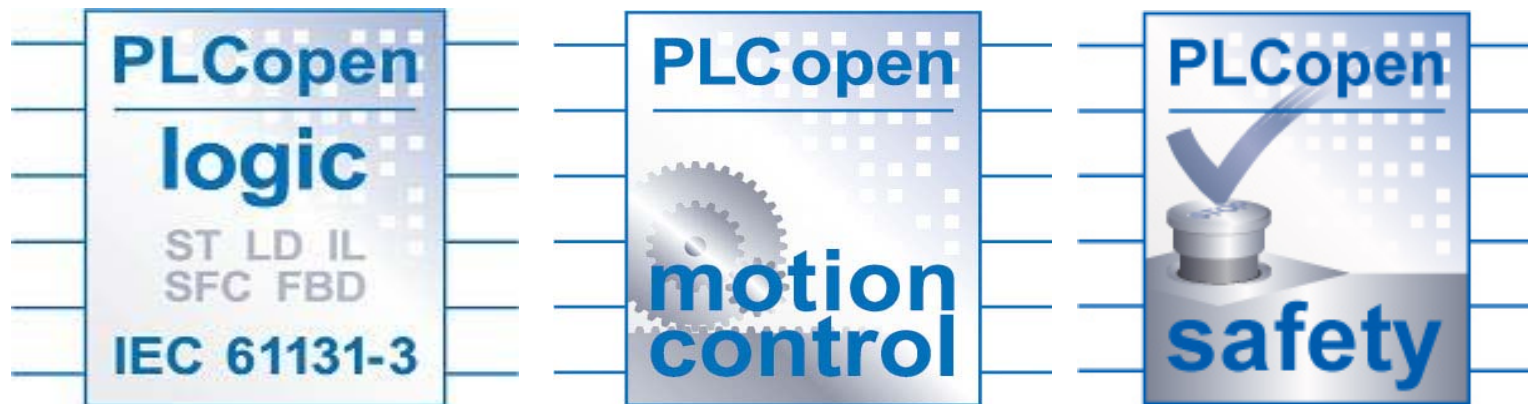

**Providing Structuring, Decomposition,
Reuse and less training**

TC3 - Benchmarking

A benchmark is a reproducible, portable test to measure the performance of a given system in comparison to other systems

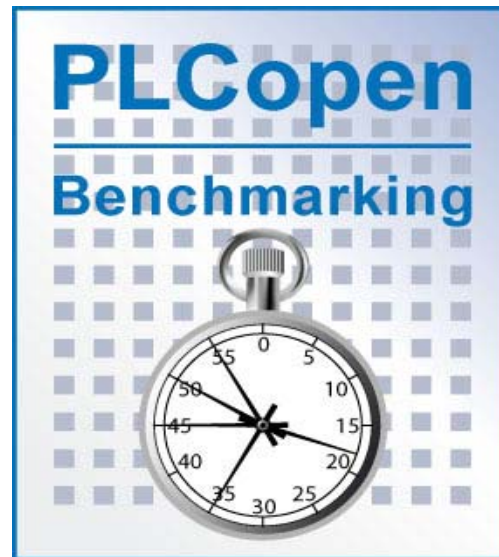

TC3 - Benchmarking

There are two main objectives to use a benchmark:

- 1. To estimate the performance of the PLC in your own application**
- 2. To compare the performance of the PLC with other PLCs and find out the specific strength and weakness of a given system**

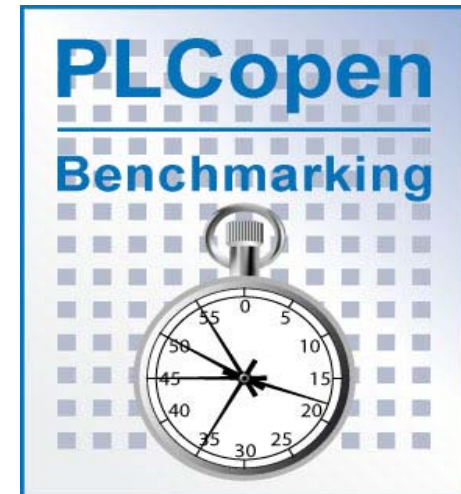

Benchmarking (TC3)

Two different sets of benchmarks defined:

- 1. 5 different types of applications, which are typical for the usage of a PLC.**
- 2. Measures each language feature of the IEC 61131-3 separately**

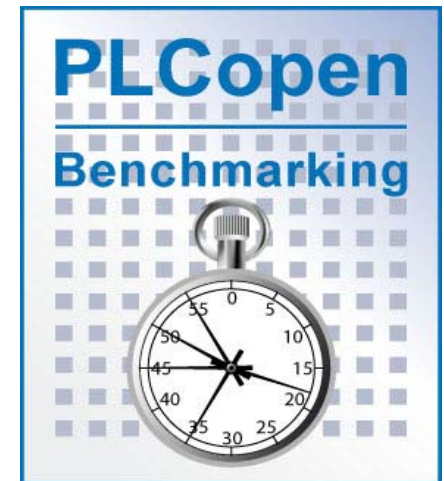

Communication (TC4)



PLCopen
for efficiency in automation

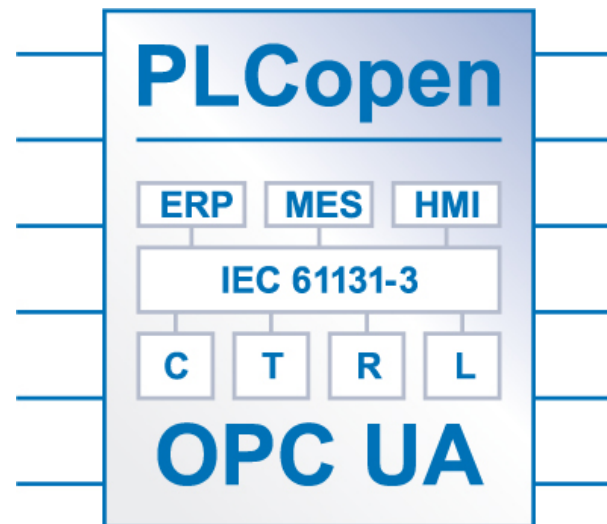

TC4 Communication

- OPC UA specifies HOW
- PLCopen specifies WHAT

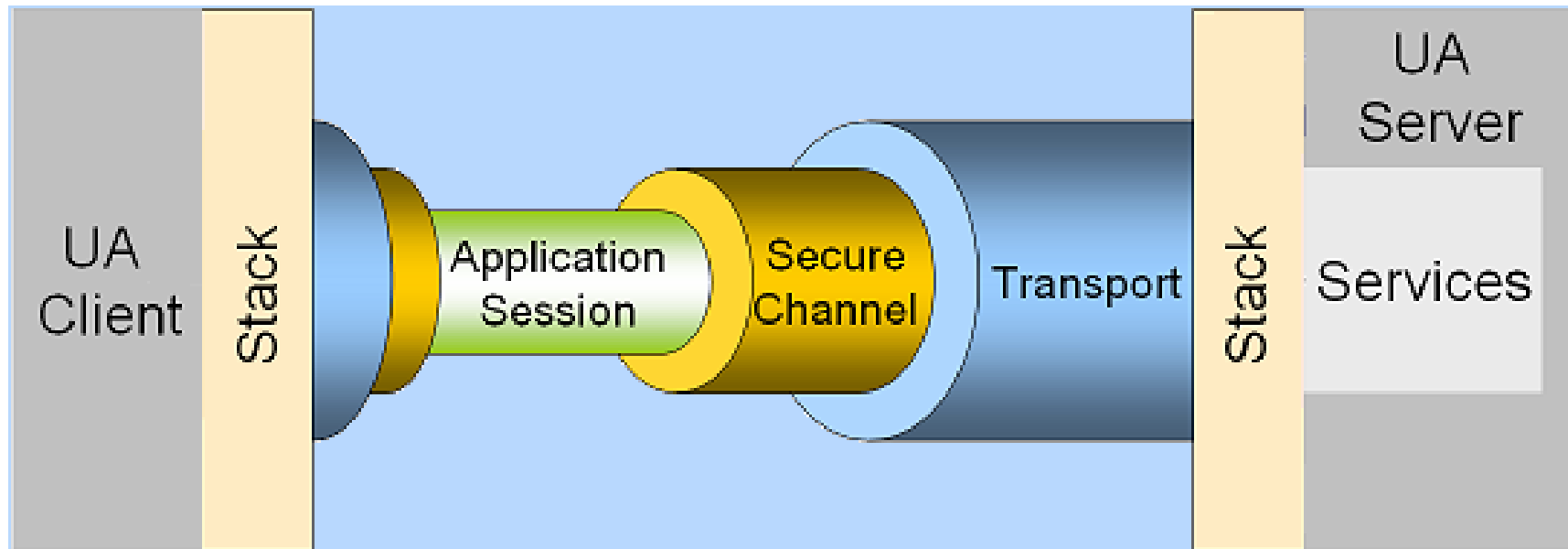

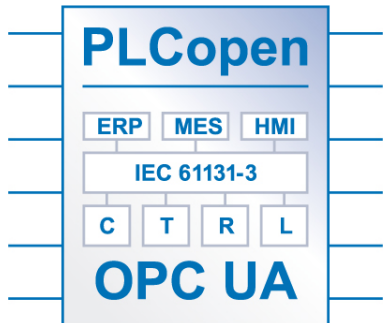
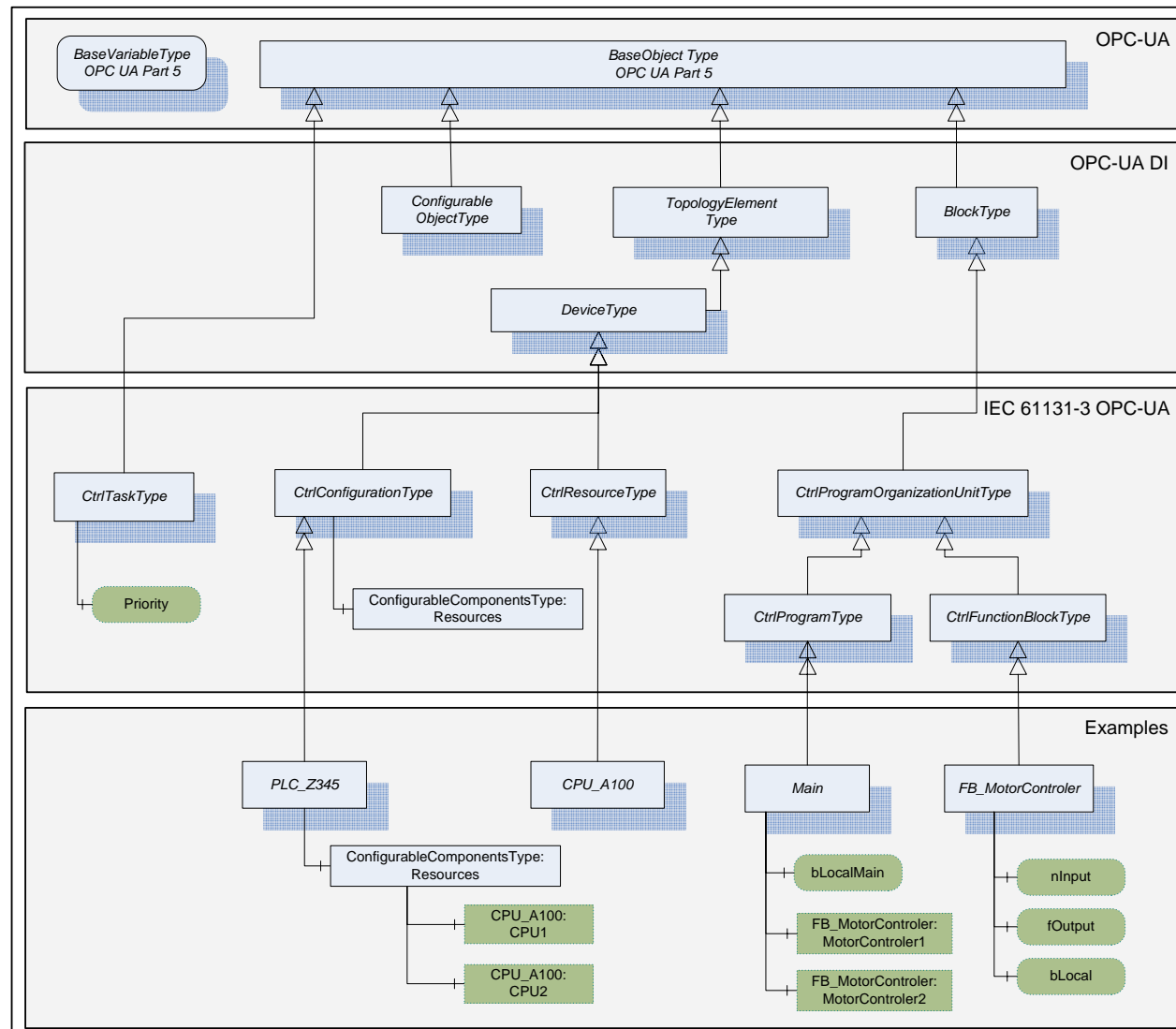

TC6 – XML

***Opening up the development environments
by specifying XML formats for IEC 61131-3***



XML (TC6)

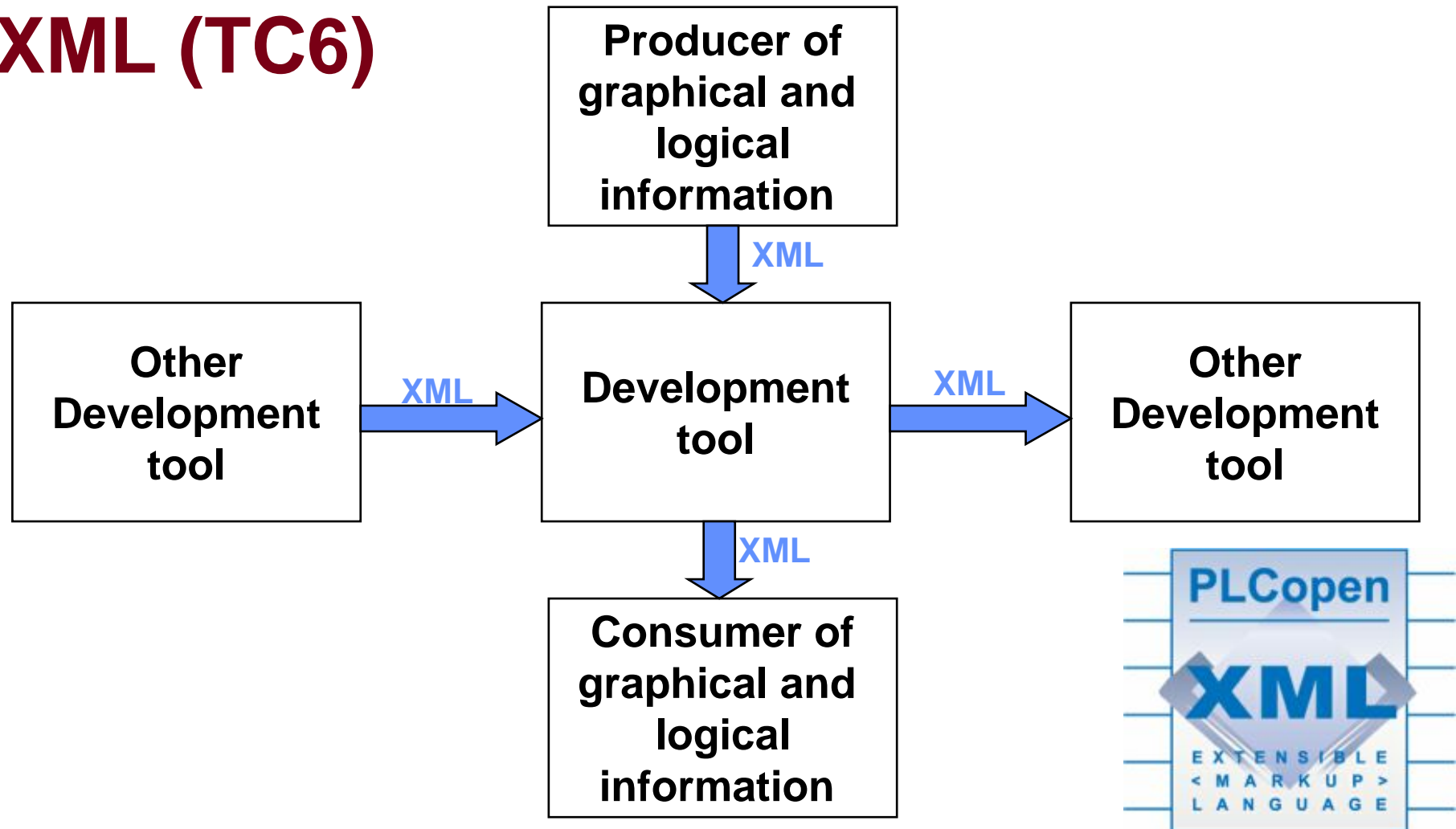

AutomationML™ describes mechatronical objects

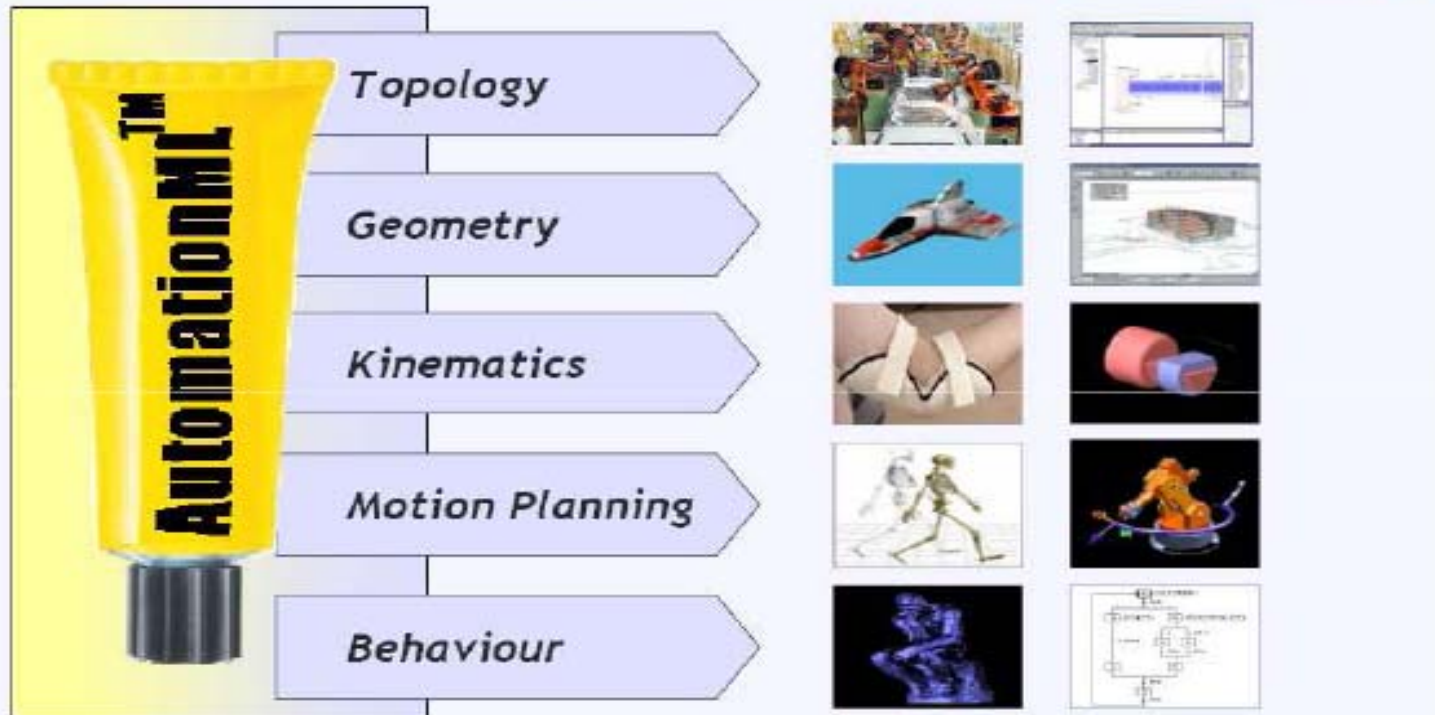

SPS/IPC/Drives Nürnberg, 27-29 Nov 2007

AutomationML - Overview









8

AutomationML™ is free and open



AutomationML™ incorporates successful standards



Aspect*	Format*	Organisation*
 Topology	CAEX (IEC 62424)	  VDE DIN
 Geometry		
 Kinematics		
 Motion Planning		
 Sequencing		 for efficiency in automation
 ...		

* Snapshot 11/2007

The link to other simulation tools

- **MatLab / Simulink**
- **Calculate / simulate complex behaviors**
- **like a 80 synchronized motors in one packaging machine**
- **or like the control of windmills**



PC2 - Training



**Important to create sufficient human
resources capable to create and innovate**

PLCopen as a World-wide association

Main Office in Europe

Office in North America

Office in China

Office in Japan

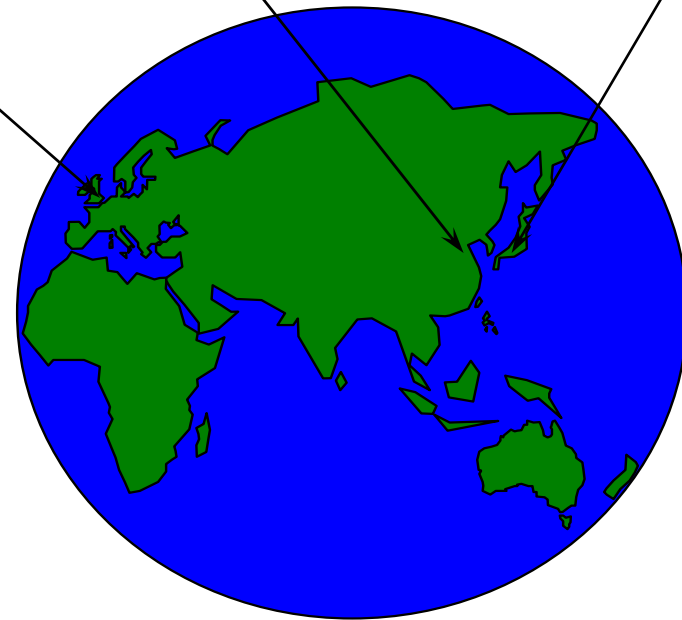
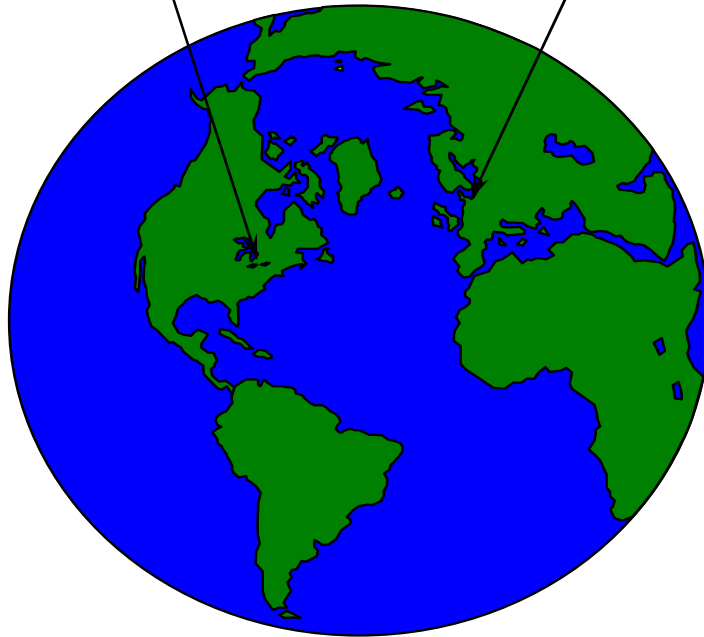

Overview PLCopen

PLCopen
logic
ST LD IL
SFC FBD
IEC 61131-3

PLCopen
motion control

PLCopen
safety

PLCopen
Benchmarking

PLCopen
XML
EXTENSIBLE
< MARKUP >
LANGUAGE

PLCopen
reusability level
No. 0000
21.06.2001
DS: 26 of 26

PLCopen
ERP MES HMI
IEC 61131-3
C T R L
OPC UA

PLCopen
Certified Training
IEC 61131-3

Percentage of Software development costs in production systems (source: McKinsey)

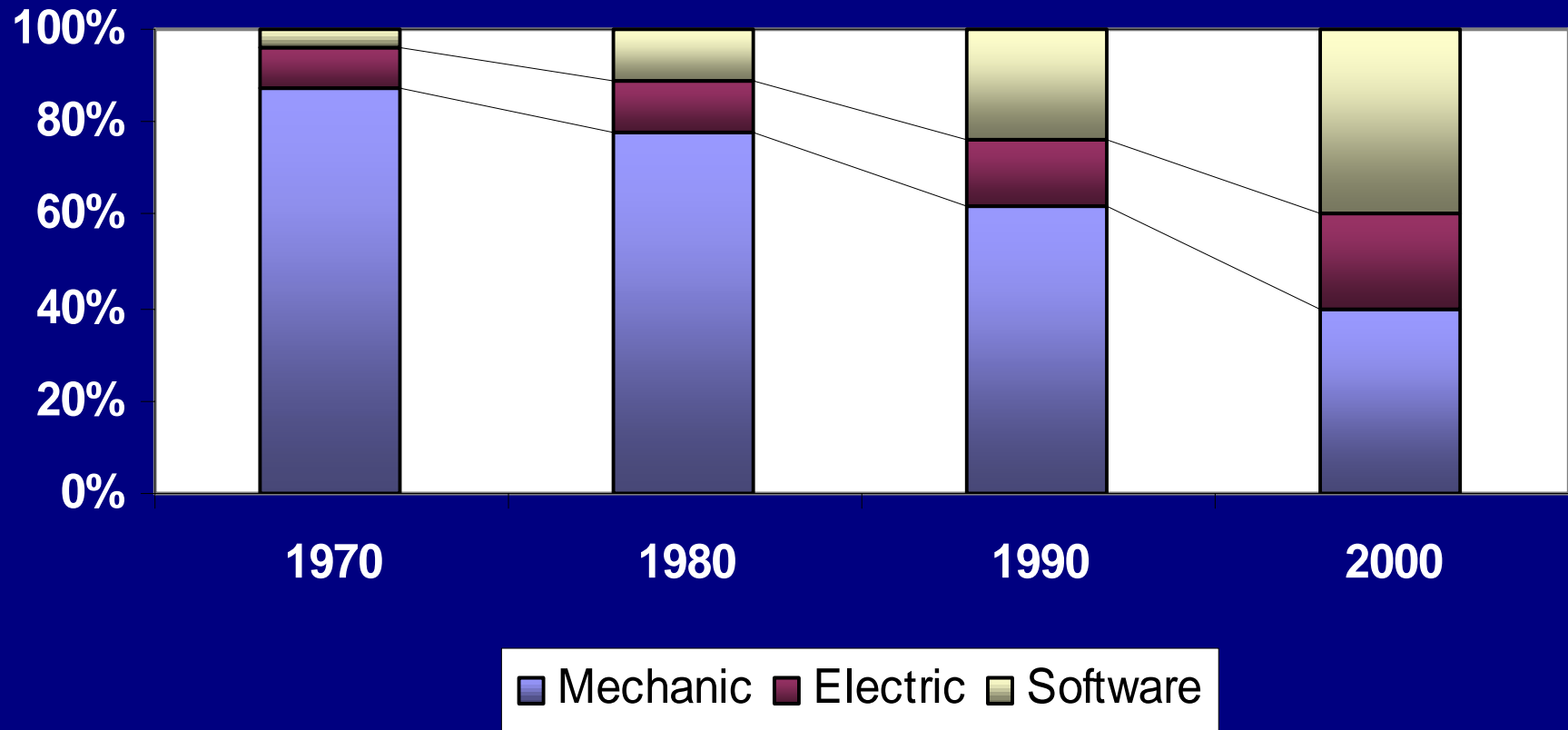

Managing Complexity

100 – 10,000 – 1mio – 100mio Lines of Code

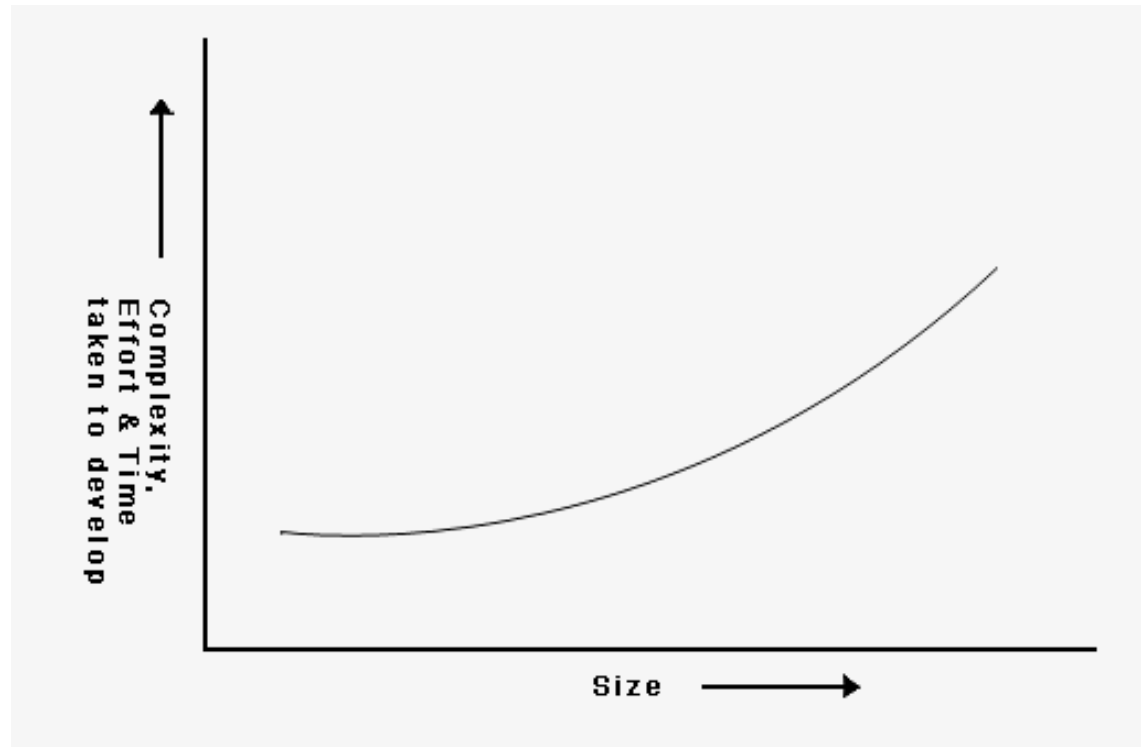

A hierarchy of abstraction

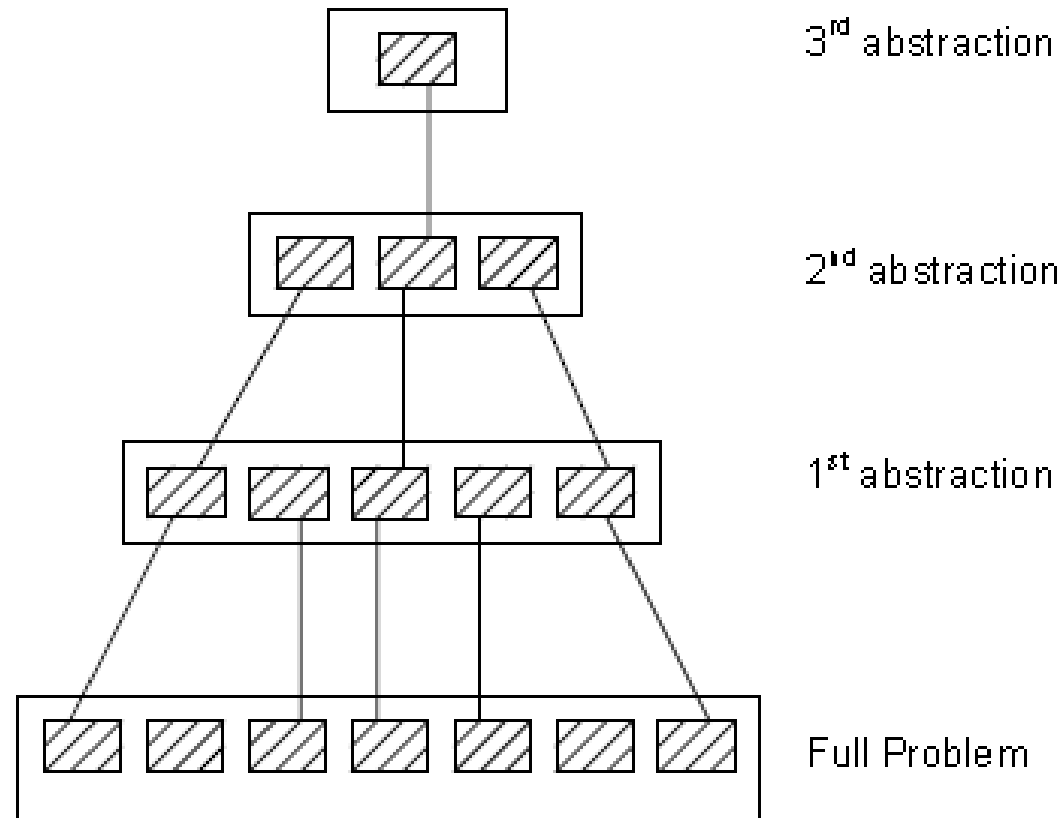

Abstraction via Function Blocks

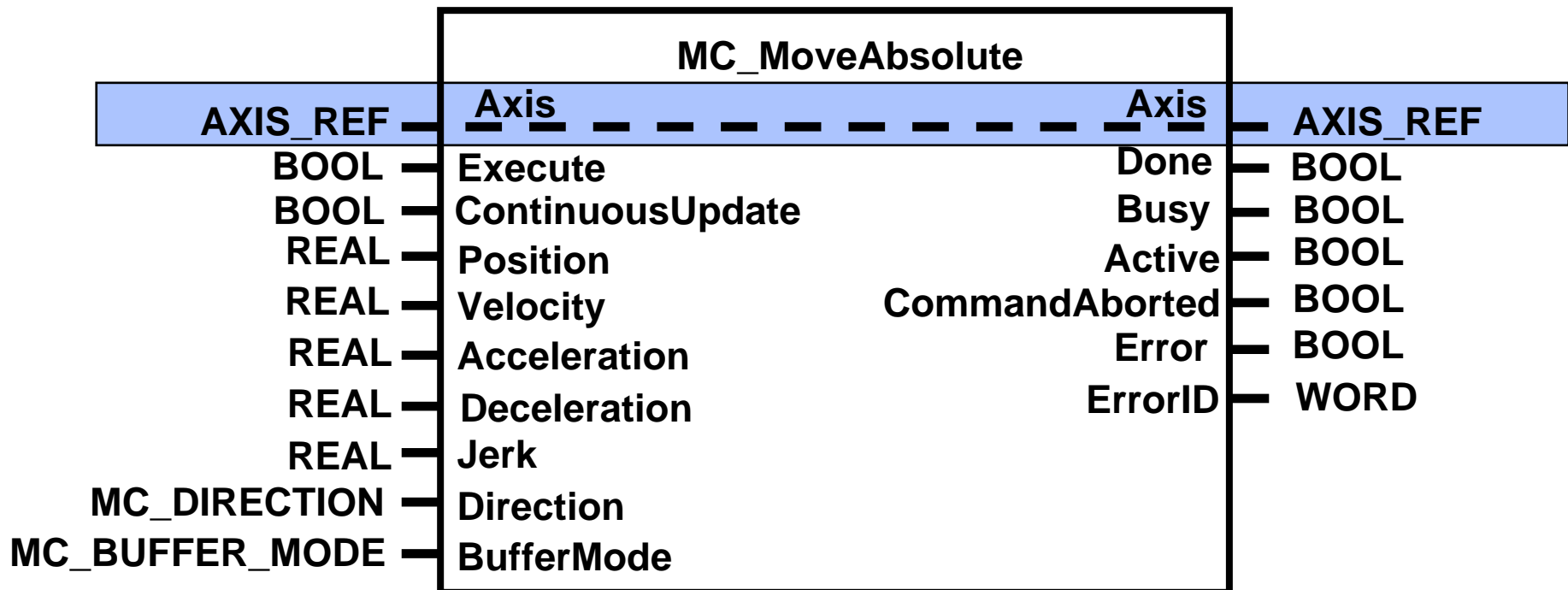

Encapsulation: Webcutting

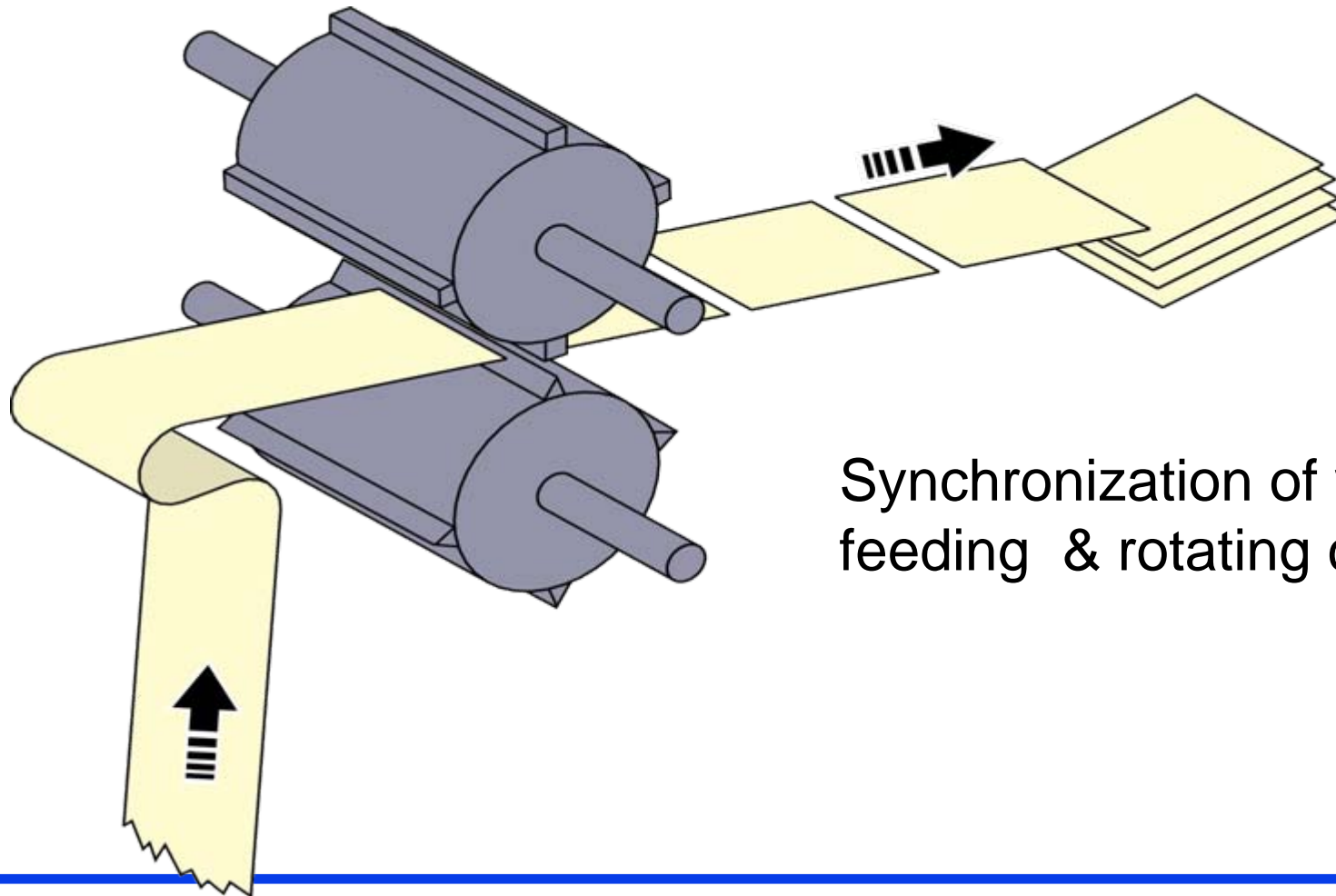

Synchronization of web
feeding & rotating cutter

Mechatronic solutions

**Mechanical
solution.**

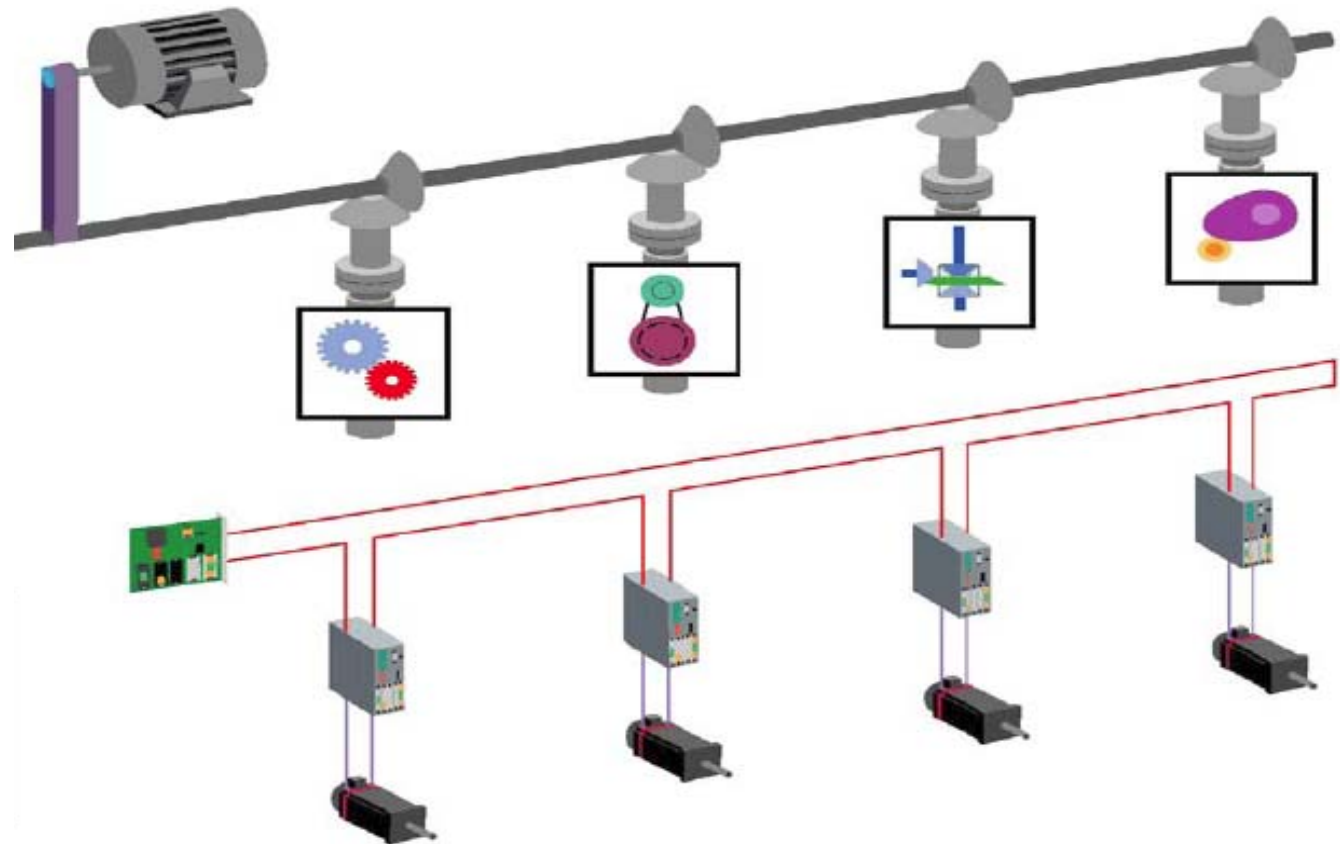

**Control
solution**

Decomposition and Reuse

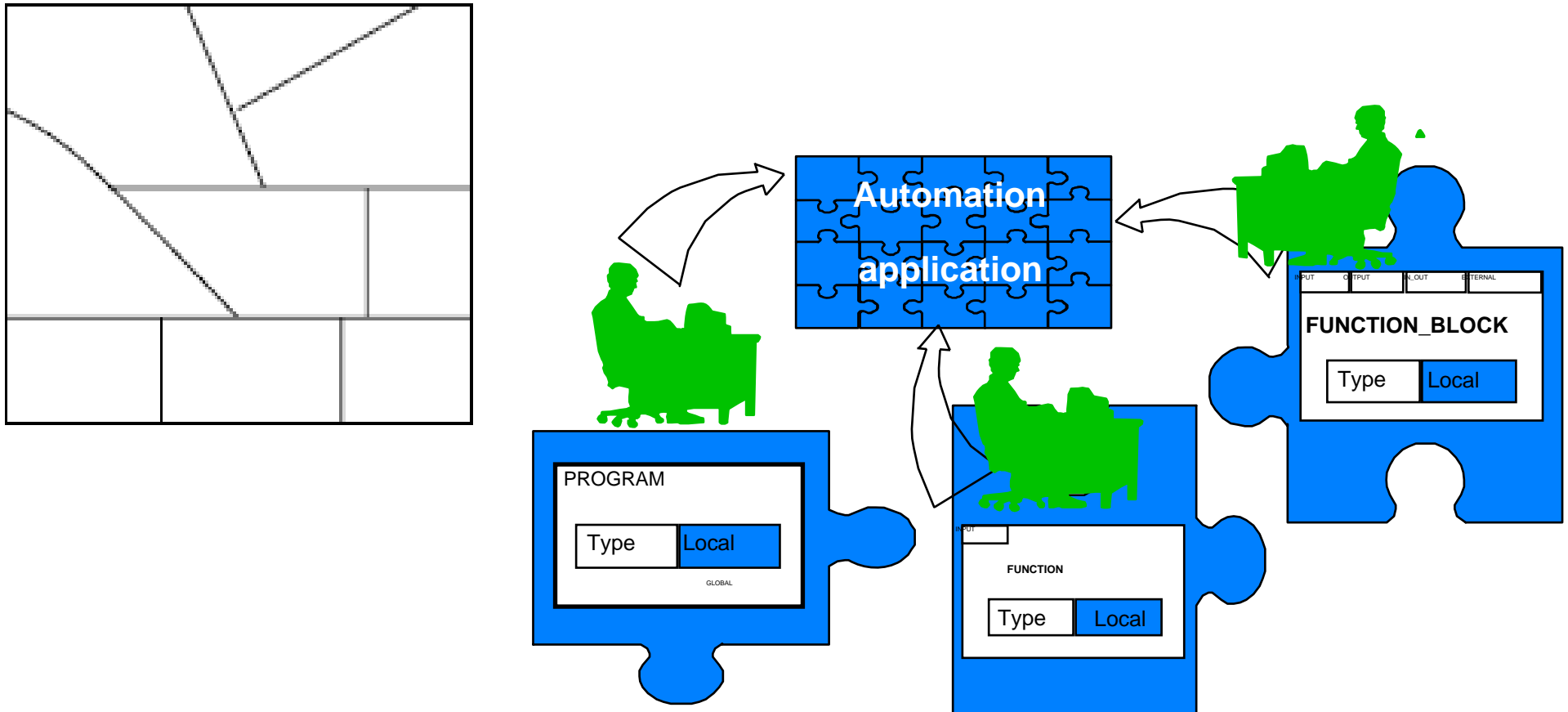

Overview



PLCopen
for efficiency in automation

**More Information...
and to download the specifications (f.o.c)**

www.plcopen.org

Free-of-Charge electronic Newsletter 'PLCopening' (in English)

email: evdwal@plcopen.org

Thanks !

End of this presentation