

IEC 61499 Current Status and Near Future Developments

**ETFA Industry Day
Toulouse, France
September 9, 2011**

James H. Christensen
IEC 61499 Maintenance
Team Leader
*james.h.christensen @
holobloc.com*

Alois Zoitl
IEC 61499 Maintenance
Team Member
zoitl @acin.tuwien.ac.at

What is IEC 61499?

- An **IEC Standard** for the use of **function blocks** in **distributed** industrial-process measurement and control systems (IPMCSs)
- Maintained by SC65B/WG15
- Adopted in 2005:
 - **Part 1, Architecture**
 - **Part 2, Software Tool Requirements**
 - **Part 4, Rules for Compliance Profiles**
- Currently in 5-year scheduled maintenance cycle
- Part 3, Tutorial Information
 - Withdrawn (obsolete), 2007

IEC SC65B/WG15 Experts

- Mr Sushil Birla (US)
- Mr James H. Christensen (US)
- Mr Marco C. Colla (CH)
- Mr Emmanuel Dela Hostria (US)
- Mr Christian Diedrich (DE)
- Mr Toshiharu Kagawa (JP)
- Mr Hindrik Koning (NL)
- Mr Robert J. Kretschmann (US)
- Mr Iko Miyazawa (JP)
- Mr Hans-Peter Otto (DE)
- Mr Francesco Russo (IT)
- Mr Hisashi Sasajima (JP)
- Mr Karlheinz Schwarz (DE)
- Mr Thomas I. Strasser (AT)
- Mr Hirotsugu Tsunematsu (JP)
- Mr Antonio Valentini (IT)
- Mr Michael J. Viste (US)
- Mr Valeriy Vyatkin (NZ)
- Mr Alois Zoitl (AT)

IEC 61499 Maintenance Status

2 nd Edition Status				
Part	CDV	RV	FDIS	PUB
1	65B/799/CDV, 2011-06-17	2011-11-18	2012-02	2012-10
2	65B/800/CDV, 2011-07-08	2011-12-09	2012-03	2012-10
4	65B/805/CDV, 2011-08-12	2012-01	2012-04	2012-11

- CDV=Committee Draft for Voting, RV=Report of Voting + Comments, FDIS=Final Draft (projected), PUB=Publication date (projected)
- IEC/TR 61499-3, Tutorial information
 - Withdrawn 2007
 - New Work Proposal (NWP) for 2nd Edition under consideration
- IEC/TS 61499-5: Proposed Extensions
 - DC (Draft for Comments) - 2012Q2(?)

IEC 61499-1 Progress

- General changes and corrections
- Improvements in ECC behavior description
- Local (temporary) variables in algorithms
- Network/Segment Types
- Interaction with Programmable Controllers
- Simplified READ/WRITE

IEC 61499-1: General Changes and Corrections

- Correction of wrong references, formatting, etc.
- Added missing management command: RESET
- Allow non started FBs to be deleted
- Allow service sequence declarations for all FB types (as anticipated in IEC 61499-2)
- Clean up of adapter usage syntax for Basic FBs
- Clean up of the mapping syntax

IEC 61499-1: ECC Behavior

- Improve description to remove ambiguities
- UML-style transition condition
 - event_input_name [guard_condition]
- The **resource shall ensure** that **no more than one input event** occurs at any given instant in time.
- Definitions for input sampling
- Clear definition of the validity of input events

IEC 61499-1: Algorithm Temporary Variables

- The declaration of an algorithm may include the declaration of temporary variables that:
 - Are only visible in the body of the algorithm;
 - Are initialized upon each invocation of the algorithm;
 - May be used and modified during execution of the algorithm; and
 - Do not have values that persist between executions of the algorithm.
- Application example: counter in for loops

IEC 61499-1: (Network) Segment Types

- Similar to Device Types

```
<?xml version="1.0" encoding="UTF-8"?>
<!DOCTYPE SegmentType SYSTEM "http://www.holobloc.com/xml/
  LibraryElement.dtd" >
<SegmentType Name="CAN" Comment="CAN Segment" >
  <Identification Standard="61499 ITA" Description="CAN ..." />
  <VersionInfo Organization="4DIAC-Consortium" Version="0.0"
    Author="4DIAC-IDE" Date="2008-07-10" />
  <VarDeclaration Name="Param" Type="WSTRING" Comment="Param" />
</SegmentType>
```

IEC 61499-1: Interaction with PLCs (Programmable Controllers)

- Improve the interaction with IEC 6113-3 PLCs
- Communication FBs
 - READ
 - UREAD
 - WRITE
- Remote Action Triggering
 - TASK

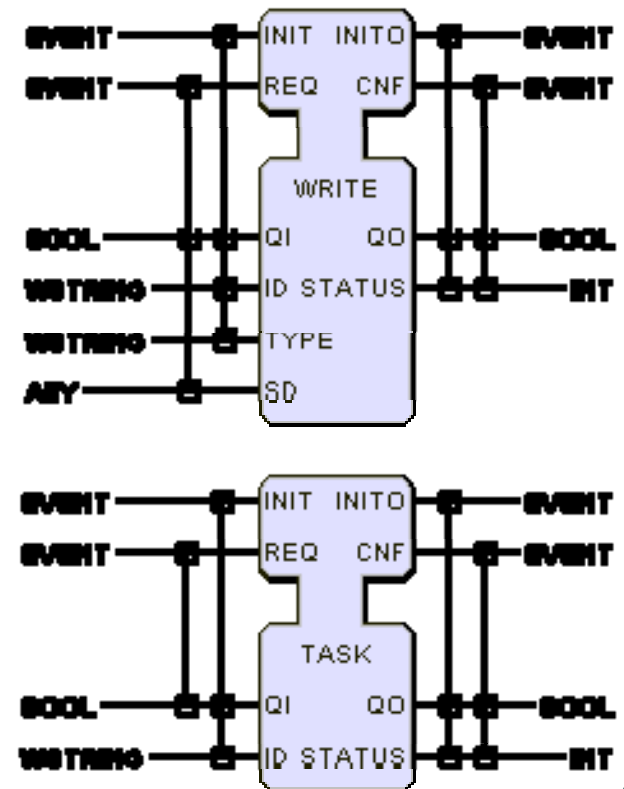

IEC 61499-1: Simplified READ/WRITE

- READ/WRITE now only applies to *parameters* of resources, devices, and top-level FB instances.
- No READ/WRITE of FB internals.
- Rationale:
Enforce good software design and enhance system performance, reliability, maintainability and safety.

IEC 61499-2: Progress

- Informative examples of software tool capabilities added.
- DTDs updated to conform with 61499-1 revision.

IEC/TS 61499-5: Proposed Extensions (1)

- Time durations in service sequences
 - Specify more strictly not only the functional behavior of FBs (Basic Composite, SIFBs, SubApps, and Adapters), e.g., event sequence
 - But also the requested timing behavior
- Universal function block
 - A FB type that combines basic and composite
 - Similar to UML models
- Adapter-related extensions
 - Merging of Adapter Connections
 - Hierarchical Adapters
 - Adapter connection over the network
- Namespaces
 - Allow a unique identification of library elements from different vendors

IEC/TS 61499-5: Proposed Extensions (2)

- XML encoding of management commands
 - Standardization of the configurability provision
 - Efficient ways of representing XML for devices (e.g., binary XML representations)
- Use of IEC 61131-3 programming language elements
 - Reuse of existing libraries within basic FBs
 - Rules for allowed and reasonable IEC 61131-3 syntax elements
- Internationalization
 - International portability of IEC 61499 library elements, textual elements such as identifiers, comments, and string literals
- Device/Resource Capabilities
 - Means for expressing hardware capabilities to be used by tools during the mapping and verification process

IEC/TS 61499-5: Proposed Extensions (3)

- Application-Specific Subapplications
 - Improve semantics and syntax of subapplications to support all application use-cases
- FB behaviours during start-up and shutdown
 - Define the behaviour in regard to cold and warm start as well as on shut down
- Hybrid IEC 61499/61131-3 platforms
 - How to better integrate the best of both sides show migration and integration paths
- Smaller Extensions
 - Specification of FB instance-specific initial values
 - Updating of DTDs to XML Schemas
 - Multi-segment connections

Summary

- Maintenance of IEC 61499 Part 1, 2, & 4 nearly completed
- Improvements towards increased usability and reduced ambiguities
- Future activities
 - IEC/TR 61499-3: Tutorial information
 - Proposed IEC/TR 61499-5: Proposed Extensions
- Comments and topics for Part 3 and 5 are welcome

IEC 61499 Current Status and Near Future Developments

Contact Speaker

Alois Zoitl

Vienna University of Technology, ACIN

Gußhausstraße 27-29 / E376

1040 Wien, AUSTRIA

+43 1 5880137683

zoitl@acin.tuwien.ac.at

www.acin.tuwien.ac.at